



DECLARATION OF PERFORMANCE NR:

DOP 13/0199 SPS

Version: V-1.2025

ACCORDING TO THE REGULATION (EU) No 574/2014 OF 21 FEBRUARY 2014

1. Unique product type identification code:

GT SP, GTR SP, GTR W SP, GTX SP

2. Intended use or uses of the construction product:

The fastening screws for sandwich panels are intended to be used for fastening sandwich panels to steel or timber substructures. The sandwich panel can either be used as wall or roof cladding or as load bearing wall and roof element.

3. Manufacturer:

Simpson Strong-Tie Etanco P.S.A., Al. Jana Pawła II 1, 81-345 Gdynia,
Address of the manufacturing plant: ul. Olsztyńska 30, 11-130 Orneta

4. Authorized representative:

Not applicable

5. System of assessment and verification of constancy of performance:

System 2+ according Annex V Regulation No 305/2013 of the European Parliament and of the Council of 9 March 2011 (Construction Product Regulation - CPR)

6. European Assessment Document:

EAD 330047-01-0602

European technical assessment:

ETA-13/0199 dated 05.08.2025

Technical Assessment Unit:

Instytut Techniki Budowlanej

Notified body or bodies:

Identification No. 1488

7. Declared performance:

Essential characteristic	Performance	European Technical Specification
Dimensions	According to Annex 2÷76 ETA 13/0199	ETA 13/0199
Characteristic tension resistance of connection $N_{R,k}$ [kN]	According to Annex 2÷74 ETA 13/0199	
Characteristic shear resistance Of connection $V_{R,k}$ [kN]	According to Annex 2÷74 ETA 13/0199	
Partial safety factor γ_M	1,33	
Coating protection according to Annex 2÷76 ETA 13/0199		
Maximum head displacement according to annex 2÷74 ETA 13/0199		

Table 1.

Self-drilling screw GT6SP Z19 5,5/6,3 x L with hexagon head and carbon steel sealing washer Ø19 mm									
Component II: t_{II} in [mm]		1,00	1,50	2,00	2,50	3,00	4,00	≥ 5,00	
Component I: $t_{0,1}$ or $t_{0,2}$ in [mm]	$V_{R,k}$ in [kN]	0,50	1,40	1,40	1,40	1,40	1,40	1,40	1,40
		0,55	1,40	1,40	1,40	1,40	1,40	1,40	1,40
		0,63	1,60	1,60	1,60	1,60	1,60	1,60	1,60
		0,75	2,10	2,10	2,10	2,10	2,10	2,10	2,10
		0,88	2,10	2,10	2,10	2,10	2,10	2,10	2,10
		1,00	2,10	2,10	2,10	2,10	2,10	2,10	2,10
	$N_{R,k}$ in [kN]	0,50	1,10	1,93	3,45	3,45	3,45	3,45	3,45
		0,55	1,10	1,93	3,45	3,45	3,45	3,45	3,45
		0,63	1,10	1,93	3,45	3,45	3,45	3,45	3,45
		0,75	1,10	1,93	3,45	3,45	3,45	3,45	3,45
		0,88	1,10	1,93	3,45	3,45	3,45	3,45	3,45
		1,00	1,10	1,93	3,45	3,45	3,45	3,45	3,45
max. head displacement u depending on the sandwich panel thickness in [mm]	30	12	12	12	12	1,5	1,5	1,5	
	40	12	12	12	12	1,5	1,5	1,5	
	50	12	12	12	12	1,5	1,5	1,5	
	60	18	18	18	18	4	4	4	
	70	18	18	18	18	4	4	4	
	80	18	18	18	18	4	4	4	
	90	23	23	23	23	10	10	10	
	100	23	23	23	23	10	10	10	
	120	23	23	23	23	10	10	10	
	≥140	23	23	23	23	10	10	10	

Component I: S280GD, S320GD or S350GD – EN 10346

Component II: S235 – EN 10025-1 S280GD, S320GD or S350GD – EN 10346

Table 2.

Self-drilling screw GT6SP Z22 5,5/6,3 x L with hexagon head and carbon steel sealing washer Ø22 mm									
Component II: t_{II} in [mm]		1,00	1,50	2,00	2,50	3,00	4,00	≥ 5,00	
Component I: $t_{I,1}$ or $t_{I,2}$ in [mm]	$V_{R,k}$ in [kN]	0,50	1,40	1,40	1,40	1,40	1,40	1,40	1,40
		0,55	1,40	1,40	1,40	1,40	1,40	1,40	1,40
		0,63	1,60	1,60	1,60	1,60	1,60	1,60	1,60
		0,75	2,10	2,10	2,10	2,10	2,10	2,10	2,10
		0,88	2,10	2,10	2,10	2,10	2,10	2,10	2,10
		1,00	2,10	2,10	2,10	2,10	2,10	2,10	2,10
	$N_{R,k}$ in [kN]	0,50	1,10	1,93	2,56	3,43	3,43	3,43	3,43
		0,55	1,10	1,93	2,56	3,43	3,43	3,43	3,43
		0,63	1,10	1,93	2,56	4,32	4,32	4,32	4,32
		0,75	1,10	1,93	2,56	6,10	6,10	6,10	6,10
		0,88	1,10	1,93	2,56	6,10	6,10	6,10	6,10
		1,00	1,10	1,93	2,56	6,10	6,10	6,10	6,10
max. head displacement u on the sandwich panel thickness in [mm]	30	12	12	12	1,5	1,5	—	1,5	
	40	12	12	12	1,5	1,5	—	1,5	
	50	12	12	12	1,5	1,5	—	1,5	
	60	18	18	18	4	4	—	4	
	70	18	18	18	4	4	—	4	
	80	18	18	18	4	4	—	4	
	90	23	23	23	10	10	—	10	
	100	23	23	23	10	10	—	10	
	120	23	23	23	10	10	—	10	
	≥ 140	23	23	23	10	10	—	10	

Component I: S280GD, S320GD or S350GD – EN 10346

Component II: S235 – EN 10025-1 S280GD, S320GD or S350GD – EN 10346

Table 3.

Self-drilling screw GT6SP Z29 5,5/6,3 x L with hexagon head and carbon steel sealing washer Ø29 mm									
Component II: t_{II} in [mm]		1,00	1,50	2,00	2,50	3,00	4,00	≥ 5,00	
Component I: $t_{N,1}$ or $t_{N,2}$ in [mm]	$V_{R,k}$ in [kN]	0,50	1,40	1,40	1,40	1,40	1,40	1,40	
		0,55	1,40	1,40	1,40	1,40	1,40	1,40	
		0,63	1,60	1,60	1,60	1,60	1,60	1,60	
		0,75	2,10	2,10	2,10	2,10	2,10	2,10	
		0,88	2,10	2,10	2,10	2,10	2,10	2,10	
		1,00	2,10	2,10	2,10	2,10	2,10	2,10	
	$N_{R,k}$ in [kN]	0,50	1,10	1,93	2,56	2,56	2,56	4,23	4,23
		0,55	1,10	1,93	2,56	2,56	2,56	4,23	4,23
		0,63	1,10	1,93	2,56	2,56	2,56	5,82	5,82
		0,75	1,10	1,93	2,56	2,56	2,56	6,35	6,35
		0,88	1,10	1,93	2,56	2,56	2,56	6,35	6,35
		1,00	1,10	1,93	2,56	2,56	2,56	6,35	6,35
max. head displacement u depending on the sandwich panel thickness in [mm]	30	12	12	12	12	1,5	1,5	1,5	
	40	12	12	12	12	1,5	1,5	1,5	
	50	12	12	12	12	1,5	1,5	1,5	
	60	18	18	18	18	4	4	4	
	70	18	18	18	18	4	4	4	
	80	18	18	18	18	4	4	4	
	90	23	23	23	23	10	10	10	
	100	23	23	23	23	10	10	10	
	120	23	23	23	23	10	10	10	
	≥ 140	23	23	23	23	10	10	10	

Component I: S280GD, S320GD or S350GD – EN 10346

Component II: S235 – EN 10025-1 S280GD, S320GD or S350GD – EN 10346

Table 4.

Self-drilling screw GTR6SP A19 5,5/6,3 x L with hexagon head and aluminum sealing washer Ø19 mm									
Component II: t_{II} in [mm]		1,00	1,50	2,00	2,50	3,00	4,00	≥ 5,00	
Component I: $t_{0,1}$ or $t_{0,2}$ in [mm]	$V_{R,k}$ in [kN]	0,50	1,40	1,40	1,40	1,40	1,40	1,40	1,40
		0,55	1,40	1,40	1,40	1,40	1,40	1,40	1,40
		0,63	1,60	1,60	1,60	1,60	1,60	1,60	1,60
		0,75	2,10	2,10	2,10	2,10	2,10	2,10	2,10
		0,88	2,10	2,10	2,10	2,10	2,10	2,10	2,10
		1,00	2,10	2,10	2,10	2,10	2,10	2,10	2,10
	$N_{R,k}$ in [kN]	0,50	1,10	1,93	3,45	3,45	3,45	3,45	3,45
		0,55	1,10	1,93	3,45	3,45	3,45	3,45	3,45
		0,63	1,10	1,93	3,45	3,45	3,45	3,45	3,45
		0,75	1,10	1,93	3,45	3,45	3,45	3,45	3,45
		0,88	1,10	1,93	3,45	3,45	3,45	3,45	3,45
		1,00	1,10	1,93	3,45	3,45	3,45	3,45	3,45
max. head displacement u depending on the sandwich panel thickness in [mm]	30	12	12	12	12	1,5	1,5	1,5	
	40	12	12	12	12	1,5	1,5	1,5	
	50	12	12	12	12	1,5	1,5	1,5	
	60	18	18	18	18	4	4	4	
	70	18	18	18	18	4	4	4	
	80	18	18	18	18	4	4	4	
	90	23	23	23	23	10	10	10	
	100	23	23	23	23	10	10	10	
	120	23	23	23	23	10	10	10	
	≥140	23	23	23	23	10	10	10	

Component I: S280GD, S320GD or S350GD – EN 10346

Component II: S235 – EN 10025-1 S280GD, S320GD or S350GD – EN 10346

Table 5.

Self-drilling screw GTR6SP A22 5,5/6,3 x L with hexagon head and aluminum sealing washer Ø22 mm								
Component II: t_{II} in [mm]		1,00	1,50	2,00	2,50	3,00	4,00	≥ 5,00
Component I: $t_{0,1}$ or $t_{0,2}$ in [mm]	$V_{R,k}$ in [kN]	0,50	1,40	1,40	1,40	1,40	1,40	1,40
		0,55	1,40	1,40	1,40	1,40	1,40	1,40
		0,63	1,60	1,60	1,60	1,60	1,60	1,60
		0,75	2,10	2,10	2,10	2,10	2,10	2,10
		0,88	2,10	2,10	2,10	2,10	2,10	2,10
		1,00	2,10	2,10	2,10	2,10	2,10	2,10
	$N_{R,k}$ in [kN]	0,50	1,10	1,93	3,45	3,45	3,45	3,45
		0,55	1,10	1,93	3,45	3,45	3,45	3,45
		0,63	1,10	1,93	3,45	3,45	3,45	3,45
		0,75	1,10	1,93	3,45	3,45	3,45	3,45
		0,88	1,10	1,93	3,45	3,45	3,45	3,45
		1,00	1,10	1,93	3,45	3,45	3,45	3,45
max. head displacement u depending on the sandwich panel thickness in [mm]	30	12	12	12	12	1,5	1,5	
	40	12	12	12	12	1,5	1,5	
	50	12	12	12	12	1,5	1,5	
	60	18	18	18	18	4	4	
	70	18	18	18	18	4	4	
	80	18	18	18	18	4	4	
	90	23	23	23	23	10	10	
	100	23	23	23	23	10	10	
	120	23	23	23	23	10	10	
	≥140	23	23	23	23	10	10	

Component I: S280GD, S320GD or S350GD – EN 10346

Component II: S235 – EN 10025-1 S280GD, S320GD or S350GD – EN 10346

Table 6.

Self-drilling screw GTR6SP A29 5,5/6,3 x L with hexagon head and aluminum sealing washer Ø29 mm									
Component II: t_{II} in [mm]		1,00	1,50	2,00	2,50	3,00	4,00	≥ 5,00	
Component I: $t_{0,1}$ or $t_{0,2}$ in [mm]	$V_{R,k}$ in [kN]	0,50	1,40	1,40	1,40	1,40	1,40	1,40	1,40
		0,55	1,40	1,40	1,40	1,40	1,40	1,40	1,40
		0,63	1,60	1,60	1,60	1,60	1,60	1,60	1,60
		0,75	2,10	2,10	2,10	2,10	2,10	2,10	2,10
		0,88	2,10	2,10	2,10	2,10	2,10	2,10	2,10
		1,00	2,10	2,10	2,10	2,10	2,10	2,10	2,10
	$N_{R,k}$ in [kN]	0,50	1,10	1,93	3,45	3,45	3,45	3,45	3,45
		0,55	1,10	1,93	3,45	3,45	3,45	3,45	3,45
		0,63	1,10	1,93	3,45	3,45	3,45	3,45	3,45
		0,75	1,10	1,93	3,45	3,45	3,45	3,45	3,45
		0,88	1,10	1,93	3,45	3,45	3,45	3,45	3,45
		1,00	1,10	1,93	3,45	3,45	3,45	3,45	3,45
max. head displacement u depending on the sandwich panel thickness in [mm]	30	12	12	12	12	1,5	1,5	1,5	
	40	12	12	12	12	1,5	1,5	1,5	
	50	12	12	12	12	1,5	1,5	1,5	
	60	18	18	18	18	4	4	4	
	70	18	18	18	18	4	4	4	
	80	18	18	18	18	4	4	4	
	90	23	23	23	23	10	10	10	
	100	23	23	23	23	10	10	10	
	120	23	23	23	23	10	10	10	
	≥140	23	23	23	23	10	10	10	

Component I: S280GD, S320GD or S350GD – EN 10346

Component II: S235 – EN 10025-1 S280GD, S320GD or S350GD – EN 10346

Table 7.

Self-drilling screw GTR6SP S19 5,5/6,3 x L with hexagon head and stainless steel sealing washer $\geq \varnothing 19$ mm									
Component II: t_{II} in [mm]		1,00	1,50	2,00	2,50	3,00	4,00	$\geq 5,00$	
Component I: $t_{0,1}$ or $t_{0,2}$ in [mm]	$V_{R,k}$ in [kN]	0,50	1,40	1,40	1,40	1,40	1,40	1,40	1,40
		0,55	1,40	1,40	1,40	1,40	1,40	1,40	1,40
		0,63	1,60	1,60	1,60	1,60	1,60	1,60	1,60
		0,75	2,10	2,10	2,10	2,10	2,10	2,10	2,10
		0,88	2,10	2,10	2,10	2,10	2,10	2,10	2,10
		1,00	2,10	2,10	2,10	2,10	2,10	2,10	2,10
	$N_{R,k}$ in [kN]	0,50	1,10	1,93	3,45	3,45	3,45	3,45	3,45
		0,55	1,10	1,93	3,45	3,45	3,45	3,45	3,45
		0,63	1,10	1,93	3,45	3,45	3,45	3,45	3,45
		0,75	1,10	1,93	3,45	3,45	3,45	3,45	3,45
		0,88	1,10	1,93	3,45	3,45	3,45	3,45	3,45
		1,00	1,10	1,93	3,45	3,45	3,45	3,45	3,45
max. head displacement u depending on the sandwich panel thickness in [mm]	30	12	12	12	12	1,5	1,5	1,5	
	40	12	12	12	12	1,5	1,5	1,5	
	50	12	12	12	12	1,5	1,5	1,5	
	60	18	18	18	18	4	4	4	
	70	18	18	18	18	4	4	4	
	80	18	18	18	18	4	4	4	
	90	23	23	23	23	10	10	10	
	100	23	23	23	23	10	10	10	
	120	23	23	23	23	10	10	10	
	≥ 140	23	23	23	23	10	10	10	

Component I: S280GD, S320GD or S350GD – EN 10346

Component II: S235 – EN 10025-1 S280GD, S320GD or S350GD – EN 10346

Table 8.

Self-drilling screw GTR6SP S22 5,5/6,3 x L with hexagon head and stainless steel sealing washer $\varnothing 22$ mm									
Component II: t_{II} in [mm]		1,00	1,50	2,00	2,50	3,00	4,00	$\geq 5,00$	
Component I: $t_{N,1}$ or $t_{N,2}$ in [mm]	$V_{R,k}$ in [kN]	0,50	1,40	1,40	1,40	1,40	1,40	1,40	1,40
		0,55	1,40	1,40	1,40	1,40	1,40	1,40	1,40
		0,63	1,60	1,60	1,60	1,60	1,60	1,60	1,60
		0,75	2,10	2,10	2,10	2,10	2,10	2,10	2,10
		0,88	2,10	2,10	2,10	2,10	2,10	2,10	2,10
		1,00	2,10	2,10	2,10	2,10	2,10	2,10	2,10
	$N_{R,k}$ in [kN]	0,50	2,56	2,56	2,56	3,43	3,43	3,43	3,43
		0,55	2,56	2,56	2,56	3,43	3,43	3,43	3,43
		0,63	2,56	2,56	2,56	4,32	4,32	4,32	4,32
		0,75	2,56	2,56	2,56	6,10	6,10	6,10	6,10
		0,88	2,56	2,56	2,56	6,10	6,10	6,10	6,10
		1,00	2,56	2,56	2,56	6,10	6,10	6,10	6,10
max. head displacement u depending on the sandwich panel thickness in [mm]	30	12	12	12	12	1,5	1,5	1,5	
	40	12	12	12	12	1,5	1,5	1,5	
	50	12	12	12	12	1,5	1,5	1,5	
	60	18	18	18	18	4	4	4	
	70	18	18	18	18	4	4	4	
	80	18	18	18	18	4	4	4	
	90	23	23	23	23	10	10	10	
	100	23	23	23	23	10	10	10	
	120	23	23	23	23	10	10	10	
	≥ 140	23	23	23	23	10	10	10	

Component I: S280GD, S320GD or S350GD – EN 10346

Component II: S235 – EN 10025-1 S280GD, S320GD or S350GD – EN 10346

Table 9.

Self-drilling screw GTR6SP S29 5,5/6,3 x L with hexagon head and stainless steel sealing washer $\varnothing 29$ mm									
Component II: t_{II} in [mm]		1,00	1,50	2,00	2,50	3,00	4,00	$\geq 5,00$	
Component I: $t_{N,1}$ or $t_{N,2}$ in [mm]	$V_{R,k}$ in [kN]	0,50	1,40	1,40	1,40	1,40	1,40	1,40	
		0,55	1,40	1,40	1,40	1,40	1,40	1,40	
		0,63	1,60	1,60	1,60	1,60	1,60	1,60	
		0,75	2,10	2,10	2,10	2,10	2,10	2,10	
		0,88	2,10	2,10	2,10	2,10	2,10	2,10	
		1,00	2,10	2,10	2,10	2,10	2,10	2,10	
	$N_{R,k}$ in [kN]	0,50	2,56	2,56	2,56	2,56	2,56	4,23	4,23
		0,55	2,56	2,56	2,56	2,56	2,56	4,23	4,23
		0,63	2,56	2,56	2,56	2,56	2,56	5,82	5,82
		0,75	2,56	2,56	2,56	2,56	2,56	6,35	6,35
		0,88	2,56	2,56	2,56	2,56	2,56	6,35	6,35
		1,00	2,56	2,56	2,56	2,56	2,56	6,35	6,35
max. head displacement u depending on the sandwich panel thickness in [mm]	30	12	12	12	12	1,5	1,5	1,5	
	40	12	12	12	12	1,5	1,5	1,5	
	50	12	12	12	12	1,5	1,5	1,5	
	60	18	18	18	18	4	4	4	
	70	18	18	18	18	4	4	4	
	80	18	18	18	18	4	4	4	
	90	23	23	23	23	10	10	10	
	100	23	23	23	23	10	10	10	
	120	23	23	23	23	10	10	10	
	≥ 140	23	23	23	23	10	10	10	

Component I: S280GD, S320GD or S350GD – EN 10346

Component II: S235 – EN 10025-1 S280GD, S320GD or S350GD – EN 10346

Table 10.

Self-drilling screw GT12SP Z19 5,5/6,3 x L with hexagon head and carbon steel sealing washer Ø19 mm									
Component II: t_{II} in [mm]		3,00	4,00	5,00	6,00	8,00	10,00	≥ 11,00	
Component I: $t_{N,1}$ or $t_{N,2}$ in [mm]	$V_{R,k}$ in [kN]	0,50	1,40	1,40	1,40	1,40	1,40	1,40	1,40
		0,55	1,40	1,40	1,40	1,40	1,40	1,40	1,40
		0,63	1,60	1,60	1,60	1,60	1,60	1,60	1,60
		0,75	2,10	2,10	2,10	2,10	2,10	2,10	2,10
		0,88	2,10	2,10	2,10	2,10	2,10	2,10	2,10
		1,00	2,10	2,10	2,10	2,10	2,10	2,10	2,10
	$N_{R,k}$ in [kN]	0,50	3,65	3,65	3,65	3,65	3,65	3,65	3,65
		0,55	3,65	3,65	3,65	3,65	3,65	3,65	3,65
		0,63	4,60	4,60	4,60	4,60	4,60	4,60	4,60
		0,75	5,45	5,45	5,45	5,45	5,45	5,45	5,45
		0,88	5,45	5,45	5,45	5,45	5,45	5,45	5,45
		1,00	5,45	5,45	5,45	5,45	5,45	5,45	5,45
max. head displacement u depending on the sandwich panel thickness in [mm]	30	1,5	1,5	1,5	1,5	1,5	1,5	1,5	
	40	1,5	1,5	1,5	1,5	1,5	1,5	1,5	
	50	1,5	1,5	1,5	1,5	1,5	1,5	1,5	
	60	4	4	4	4	4	4	4	
	70	4	4	4	4	4	4	4	
	80	4	4	4	4	4	4	4	
	90	6	6	6	6	6	6	6	
	100	6	6	6	6	6	6	6	
	120	6	6	6	6	6	6	6	
	≥ 140	6	6	6	6	6	6	6	

Component I: S280GD, S320GD or S350GD – EN 10346

Component II: S235 – EN 10025-1 S280GD, S320GD or S350GD – EN 10346

Table 11.

Self-drilling screw GT12SP Z22 5,5/6,3 x L with hexagon head and carbon steel sealing washer Ø22 mm									
Component II: t_{II} in [mm]		3,00	4,00	5,00	6,00	8,00	10,00	≥ 11,00	
Component I: $t_{N,1}$ or $t_{N,2}$ in [mm]	$V_{R,k}$ in [kN]	0,50	1,40	1,40	1,40	1,40	1,40	1,40	1,40
		0,55	1,40	1,40	1,40	1,40	1,40	1,40	1,40
		0,63	1,60	1,60	1,60	1,60	1,60	1,60	1,60
		0,75	2,10	2,10	2,10	2,10	2,10	2,10	2,10
		0,88	2,10	2,10	2,10	2,10	2,10	2,10	2,10
		1,00	2,10	2,10	2,10	2,10	2,10	2,10	2,10
	$N_{R,k}$ in [kN]	0,50	3,43	3,43	3,43	3,43	3,43	3,43	3,43
		0,55	3,43	3,43	3,43	3,43	3,43	3,43	3,43
		0,63	4,32	4,32	4,32	4,32	4,32	4,32	4,32
		0,75	6,10	6,10	6,10	6,10	6,10	6,10	6,10
		0,88	6,10	6,10	6,10	6,10	6,10	6,10	6,10
		1,00	6,10	6,10	6,10	6,10	6,10	6,10	6,10
max. head displacement u depending on the sandwich panel thickness in [mm]	30	1,5	1,5	1,5	1,5	1,5	1,5	1,5	
	40	1,5	1,5	1,5	1,5	1,5	1,5	1,5	
	50	1,5	1,5	1,5	1,5	1,5	1,5	1,5	
	60	4	4	4	4	4	4	4	
	70	4	4	4	4	4	4	4	
	80	4	4	4	4	4	4	4	
	90	6	6	6	6	6	6	6	
	100	6	6	6	6	6	6	6	
	120	6	6	6	6	6	6	6	
	≥ 140	6	6	6	6	6	6	6	

Component I: S280GD, S320GD or S350GD – EN 10346

Component II: S235 – EN 10025-1 S280GD, S320GD or S350GD – EN 10346

Table 12.

Self-drilling screw GT12SP Z29 5,5/6,3 x L with hexagon head and carbon steel sealing washer Ø29 mm								
Component II: t_{II} in [mm]		3,00	4,00	5,00	6,00	8,00	10,00	≥ 11,00
Component I: $t_{N,1}$ or $t_{N,2}$ in [mm]	$V_{R,k}$ in [kN]	0,50	1,40	1,40	1,40	1,40	1,40	1,40
		0,55	1,40	1,40	1,40	1,40	1,40	1,40
		0,63	1,60	1,60	1,60	1,60	1,60	1,60
		0,75	2,10	2,10	2,10	2,10	2,10	2,10
		0,88	2,10	2,10	2,10	2,10	2,10	2,10
		1,00	2,10	2,10	2,10	2,10	2,10	2,10
	$N_{R,k}$ in [kN]	0,50	4,23	4,23	4,23	4,23	4,23	4,23
		0,55	4,23	4,23	4,23	4,23	4,23	4,23
		0,63	5,82	5,82	5,82	5,82	5,82	5,82
		0,75	6,35	6,35	6,35	6,35	6,35	6,35
		0,88	6,35	6,35	6,35	6,35	6,35	6,35
		1,00	6,35	6,35	6,35	6,35	6,35	6,35
max. head displacement u depending on the sandwich panel thickness in [mm]	30	1,5	1,5	1,5	1,5	1,5	1,5	
	40	1,5	1,5	1,5	1,5	1,5	1,5	
	50	1,5	1,5	1,5	1,5	1,5	1,5	
	60	4	4	4	4	4	4	
	70	4	4	4	4	4	4	
	80	4	4	4	4	4	4	
	90	6	6	6	6	6	6	
	100	6	6	6	6	6	6	
	120	6	6	6	6	6	6	
	≥ 140	6	6	6	6	6	6	

Component I: S280GD, S320GD or S350GD – EN 10346

Component II: S235 – EN 10025-1 S280GD, S320GD or S350GD – EN 10346

Table 13.

Self-drilling screw GTR12SP A19 5,5/6,3 x L with hexagon head and aluminum sealing washer Ø19 mm									
Component II: t_{II} in [mm]		3,00	4,00	5,00	6,00	8,00	10,00	≥ 11,00	
Component I: $t_{N,1}$ or $t_{N,2}$ in [mm]	$V_{R,k}$ in [kN]	0,50	1,40	1,40	1,40	1,40	1,40	1,40	1,40
		0,55	1,40	1,40	1,40	1,40	1,40	1,40	1,40
		0,63	1,60	1,60	1,60	1,60	1,60	1,60	1,60
		0,75	2,10	2,10	2,10	2,10	2,10	2,10	2,10
		0,88	2,10	2,10	2,10	2,10	2,10	2,10	2,10
		1,00	2,10	2,10	2,10	2,10	2,10	2,10	2,10
	$N_{R,k}$ in [kN]	0,50	3,67	3,67	3,67	3,67	3,67	3,67	3,67
		0,55	3,67	3,67	3,67	3,67	3,67	3,67	3,67
		0,63	4,11	4,11	4,11	4,11	4,11	4,11	4,11
		0,75	5,28	5,28	5,28	5,28	5,28	5,28	5,28
		0,88	5,28	5,28	5,28	5,28	5,28	5,28	5,28
		1,00	5,28	5,28	5,28	5,28	5,28	5,28	5,28
max. head displacement u depending on the sandwich panel thickness in [mm]	30	1,5	1,5	1,5	1,5	1,5	1,5	1,5	
	40	1,5	1,5	1,5	1,5	1,5	1,5	1,5	
	50	1,5	1,5	1,5	1,5	1,5	1,5	1,5	
	60	4	4	4	4	4	4	4	
	70	4	4	4	4	4	4	4	
	80	4	4	4	4	4	4	4	
	90	6	6	6	6	6	6	6	
	100	6	6	6	6	6	6	6	
	120	6	6	6	6	6	6	6	
	≥ 140	6	6	6	6	6	6	6	

Component I: S280GD, S320GD or S350GD – EN 10346

Component II: S235 – EN 10025-1 S280GD, S320GD or S350GD – EN 10346

Table 14.

Self-drilling screw GTR12SP A22 5,5/6,3 x L with hexagon head and aluminum sealing washer Ø22 mm									
Component II: t_{II} in [mm]		3,00	4,00	5,00	6,00	8,00	10,00	≥ 11,00	
Component I: $t_{N,1}$ or $t_{N,2}$ in [mm]	$V_{R,k}$ in [kN]	0,50	1,40	1,40	1,40	1,40	1,40	1,40	1,40
		0,55	1,40	1,40	1,40	1,40	1,40	1,40	1,40
		0,63	1,60	1,60	1,60	1,60	1,60	1,60	1,60
		0,75	2,10	2,10	2,10	2,10	2,10	2,10	2,10
		0,88	2,10	2,10	2,10	2,10	2,10	2,10	2,10
		1,00	2,10	2,10	2,10	2,10	2,10	2,10	2,10
	$N_{R,k}$ in [kN]	0,50	3,67	3,67	3,67	3,67	3,67	3,67	3,67
		0,55	3,67	3,67	3,67	3,67	3,67	3,67	3,67
		0,63	4,11	4,11	4,11	4,11	4,11	4,11	4,11
		0,75	5,28	5,28	5,28	5,28	5,28	5,28	5,28
		0,88	5,28	5,28	5,28	5,28	5,28	5,28	5,28
		1,00	5,28	5,28	5,28	5,28	5,28	5,28	5,28
max. head displacement u depending on the sandwich panel thickness in [mm]	30	1,5	1,5	1,5	1,5	1,5	1,5	1,5	
	40	1,5	1,5	1,5	1,5	1,5	1,5	1,5	
	50	1,5	1,5	1,5	1,5	1,5	1,5	1,5	
	60	4	4	4	4	4	4	4	
	70	4	4	4	4	4	4	4	
	80	4	4	4	4	4	4	4	
	90	6	6	6	6	6	6	6	
	100	6	6	6	6	6	6	6	
	120	6	6	6	6	6	6	6	
	≥ 140	6	6	6	6	6	6	6	

Component I: S280GD, S320GD or S350GD – EN 10346

Component II: S235 – EN 10025-1 S280GD, S320GD or S350GD – EN 10346

Table 15.

Self-drilling screw GTR12SP A29 5,5/6,3 x L with hexagon head and aluminum sealing washer Ø29 mm									
Component II: t_{II} in [mm]		3,00	4,00	5,00	6,00	8,00	10,00	≥ 11,00	
Component I: $t_{N,1}$ or $t_{N,2}$ in [mm]	$V_{R,k}$ in [kN]	0,50	1,40	1,40	1,40	1,40	1,40	1,40	1,40
		0,55	1,40	1,40	1,40	1,40	1,40	1,40	1,40
		0,63	1,60	1,60	1,60	1,60	1,60	1,60	1,60
		0,75	2,10	2,10	2,10	2,10	2,10	2,10	2,10
		0,88	2,10	2,10	2,10	2,10	2,10	2,10	2,10
		1,00	2,10	2,10	2,10	2,10	2,10	2,10	2,10
	$N_{R,k}$ in [kN]	0,50	3,67	3,67	3,67	3,67	3,67	3,67	3,67
		0,55	3,67	3,67	3,67	3,67	3,67	3,67	3,67
		0,63	4,11	4,11	4,11	4,11	4,11	4,11	4,11
		0,75	5,28	5,28	5,28	5,28	5,28	5,28	5,28
		0,88	5,28	5,28	5,28	5,28	5,28	5,28	5,28
		1,00	5,28	5,28	5,28	5,28	5,28	5,28	5,28
max. head displacement u depending on the sandwich panel thickness in [mm]	30	1,5	1,5	1,5	1,5	1,5	1,5	1,5	
	40	1,5	1,5	1,5	1,5	1,5	1,5	1,5	
	50	1,5	1,5	1,5	1,5	1,5	1,5	1,5	
	60	4	4	4	4	4	4	4	
	70	4	4	4	4	4	4	4	
	80	4	4	4	4	4	4	4	
	90	6	6	6	6	6	6	6	
	100	6	6	6	6	6	6	6	
	120	6	6	6	6	6	6	6	
	≥ 140	6	6	6	6	6	6	6	

Component I: S280GD, S320GD or S350GD – EN 10346

Component II: S235 – EN 10025-1 S280GD, S320GD or S350GD – EN 10346

Table 16.

Self-drilling screw GTR12SP S19 5,5/6,3 x L with hexagon head and stainless steel sealing washer $\varnothing 19$ mm								
Component II: t_{II} in [mm]		3,00	4,00	5,00	6,00	8,00	10,00	$\geq 11,00$
Component I: $t_{N,1}$ or $t_{N,2}$ in [mm]	$V_{R,k}$ in [kN]	0,50	1,40	1,40	1,40	1,40	1,40	1,40
		0,55	1,40	1,40	1,40	1,40	1,40	1,40
		0,63	1,60	1,60	1,60	1,60	1,60	1,60
		0,75	2,10	2,10	2,10	2,10	2,10	2,10
		0,88	2,10	2,10	2,10	2,10	2,10	2,10
		1,00	2,10	2,10	2,10	2,10	2,10	2,10
	$N_{R,k}$ in [kN]	0,50	3,67	3,67	3,67	3,67	3,67	3,67
		0,55	3,67	3,67	3,67	3,67	3,67	3,67
		0,63	4,11	4,11	4,11	4,11	4,11	4,11
		0,75	5,28	5,28	5,28	5,28	5,28	5,28
		0,88	5,28	5,28	5,28	5,28	5,28	5,28
		1,00	5,28	5,28	5,28	5,28	5,28	5,28
max. head displacement u depending on the sandwich panel thickness in [mm]	30	1,5	1,5	1,5	1,5	1,5	1,5	
	40	1,5	1,5	1,5	1,5	1,5	1,5	
	50	1,5	1,5	1,5	1,5	1,5	1,5	
	60	4	4	4	4	4	4	
	70	4	4	4	4	4	4	
	80	4	4	4	4	4	4	
	90	6	6	6	6	6	6	
	100	6	6	6	6	6	6	
	120	6	6	6	6	6	6	
	≥ 140	6	6	6	6	6	6	

Component I: S280GD, S320GD or S350GD – EN 10346

Component II: S235 – EN 10025-1 S280GD, S320GD or S350GD – EN 10346

Table 17.

Self-drilling screw GTR12SP S22 5,5/6,3 x L with hexagon head and stainless steel sealing washer $\varnothing 22$ mm								
Component II: t_{II} in [mm]		3,00	4,00	5,00	6,00	8,00	10,00	$\geq 11,00$
Component I: $t_{N,1}$ or $t_{N,2}$ in [mm]	$V_{R,k}$ in [kN]	0,50	1,40	1,40	1,40	1,40	1,40	1,40
		0,55	1,40	1,40	1,40	1,40	1,40	1,40
		0,63	1,60	1,60	1,60	1,60	1,60	1,60
		0,75	2,10	2,10	2,10	2,10	2,10	2,10
		0,88	2,10	2,10	2,10	2,10	2,10	2,10
		1,00	2,10	2,10	2,10	2,10	2,10	2,10
	$N_{R,k}$ in [kN]	0,50	3,43	3,43	3,43	3,43	3,43	3,43
		0,55	3,43	3,43	3,43	3,43	3,43	3,43
		0,63	4,32	4,32	4,32	4,32	4,32	4,32
		0,75	6,10	6,10	6,10	6,10	6,10	6,10
		0,88	6,10	6,10	6,10	6,10	6,10	6,10
		1,00	6,10	6,10	6,10	6,10	6,10	6,10
max. head displacement u depending on the sandwich panel thickness in [mm]	30	1,5	1,5	1,5	1,5	1,5	1,5	
	40	1,5	1,5	1,5	1,5	1,5	1,5	
	50	1,5	1,5	1,5	1,5	1,5	1,5	
	60	4	4	4	4	4	4	
	70	4	4	4	4	4	4	
	80	4	4	4	4	4	4	
	90	6	6	6	6	6	6	
	100	6	6	6	6	6	6	
	120	6	6	6	6	6	6	
	≥ 140	6	6	6	6	6	6	

Component I: S280GD, S320GD or S350GD – EN 10346

Component II: S235 – EN 10025-1 S280GD, S320GD or S350GD – EN 10346

Table 18.

Self-drilling screw GTR12SP S29 5,5/6,3 x L with hexagon head and stainless steel sealing washer $\varnothing 29$ mm								
Component II: t_{II} in [mm]		3,00	4,00	5,00	6,00	8,00	10,00	$\geq 11,00$
Component I: $t_{N,1}$ or $t_{N,2}$ in [mm]	$V_{R,k}$ in [kN]	0,50	1,40	1,40	1,40	1,40	1,40	1,40
		0,55	1,40	1,40	1,40	1,40	1,40	1,40
		0,63	1,60	1,60	1,60	1,60	1,60	1,60
		0,75	2,10	2,10	2,10	2,10	2,10	2,10
		0,88	2,10	2,10	2,10	2,10	2,10	2,10
		1,00	2,10	2,10	2,10	2,10	2,10	2,10
	$N_{R,k}$ in [kN]	0,50	4,23	4,23	4,23	4,23	4,23	4,23
		0,55	4,23	4,23	4,23	4,23	4,23	4,23
		0,63	5,82	5,82	5,82	5,82	5,82	5,82
		0,75	6,35	6,35	6,35	6,35	6,35	6,35
		0,88	6,35	6,35	6,35	6,35	6,35	6,35
		1,00	6,35	6,35	6,35	6,35	6,35	6,35
max. head displacement u depending on the sandwich panel thickness in [mm]	30	1,5	1,5	1,5	1,5	1,5	1,5	
	40	1,5	1,5	1,5	1,5	1,5	1,5	
	50	1,5	1,5	1,5	1,5	1,5	1,5	
	60	4	4	4	4	4	4	
	70	4	4	4	4	4	4	
	80	4	4	4	4	4	4	
	90	6	6	6	6	6	6	
	100	6	6	6	6	6	6	
	120	6	6	6	6	6	6	
	≥ 140	6	6	6	6	6	6	

Component I: S280GD, S320GD or S350GD – EN 10346

Component II: S235 – EN 10025-1 S280GD, S320GD or S350GD – EN 10346

Table 19.

Self-drilling screw GT16SP Z19 6,3/7,0 x L with hexagon head and carbon steel sealing washer Ø19 mm									
Component II: t_{II} in [mm]		4,00	5,00	6,00	8,00	10,00	12,00	14,00	≥ 15,00
Component I: $t_{N,1}$ or $t_{N,2}$ in [mm]	$V_{R,k}$ in [kN]	0,50	1,29	1,29	1,29	1,29	1,29	1,29	1,29
		0,55	1,29	1,29	1,29	1,29	1,29	1,29	1,29
		0,63	2,35	2,35	2,35	2,35	2,35	2,35	2,35
		0,75	2,50	2,50	2,50	2,50	2,50	2,50	2,50
		0,88	2,50	2,50	2,50	2,50	2,50	2,50	2,50
		1,00	2,50	2,50	2,50	2,50	2,50	2,50	2,50
	$N_{R,k}$ in [kN]	0,50	3,65	3,65	3,65	3,65	3,65	3,65	3,65
		0,55	3,65	3,65	3,65	3,65	3,65	3,65	3,65
		0,63	4,60	4,60	4,60	4,60	4,60	4,60	4,60
		0,75	5,45	5,45	5,45	5,45	5,45	5,45	5,45
		0,88	5,45	5,45	5,45	5,45	5,45	5,45	5,45
		1,00	5,45	5,45	5,45	5,45	5,45	5,45	5,45
max. head displacement u depending on the sandwich panel thickness in [mm]	30	1	1	1	1	1	1	1	
	40	1	1	1	1	1	1	1	
	50	1	1	1	1	1	1	1	
	60	2,5	2,5	2,5	2,5	2,5	2,5	2,5	
	70	2,5	2,5	2,5	2,5	2,5	2,5	2,5	
	80	2,5	2,5	2,5	2,5	2,5	2,5	2,5	
	90	4	4	4	4	4	4	4	
	100	4	4	4	4	4	4	4	
	120	4	4	4	4	4	4	4	
	≥ 140	4	4	4	4	4	4	4	

Component I: S280GD, S320GD or S350GD – EN 10346

Component II: S235 – EN 10025-1 S280GD, S320GD or S350GD – EN 10346

Table 20.

Self-drilling screw GT16SP Z22 6,3/7,0 x L with hexagon head and carbon steel sealing washer Ø22 mm									
Component II: t_{II} in [mm]		4,00	5,00	6,00	8,00	10,00	12,00	14,00	≥ 15,00
Component I: $t_{N,1}$ or $t_{N,2}$ in [mm]	$V_{R,k}$ in [kN]	0,50	1,29	1,29	1,29	1,29	1,29	1,29	1,29
		0,55	1,29	1,29	1,29	1,29	1,29	1,29	1,29
		0,63	2,35	2,35	2,35	1,69	1,69	1,69	1,69
		0,75	2,50	2,50	2,50	1,96	1,96	1,96	1,96
		0,88	2,50	2,50	2,50	1,96	1,96	1,96	1,96
		1,00	2,50	2,50	2,50	1,96	1,96	1,96	1,96
	$N_{R,k}$ in [kN]	0,50	3,65	3,65	3,65	3,43	3,43	3,43	3,43
		0,55	3,65	3,65	3,65	3,43	3,43	3,43	3,43
		0,63	4,60	4,60	4,60	4,32	4,32	4,32	4,32
		0,75	5,45	5,45	5,45	6,10	6,10	6,10	6,10
		0,88	5,45	5,45	5,45	6,10	6,10	6,10	6,10
		1,00	5,45	5,45	5,45	6,10	6,10	6,10	6,10
max. head displacement u depending on the sandwich panel thickness in [mm]	30	1	1	1	1	1	1	1	
	40	1	1	1	1	1	1	1	
	50	1	1	1	1	1	1	1	
	60	2,5	2,5	2,5	2,5	2,5	2,5	2,5	
	70	2,5	2,5	2,5	2,5	2,5	2,5	2,5	
	80	2,5	2,5	2,5	2,5	2,5	2,5	2,5	
	90	4	4	4	4	4	4	4	
	100	4	4	4	4	4	4	4	
	120	4	4	4	4	4	4	4	
	≥ 140	4	4	4	4	4	4	4	

Component I: S280GD, S320GD or S350GD – EN 10346

Component II: S235 – EN 10025-1 S280GD, S320GD or S350GD – EN 10346

Table 21.

Self-drilling screw GT16SP Z29 6,3/7,0 x L with hexagon head and carbon steel sealing washer Ø29 mm									
Component II: t_{II} in [mm]		4,00	5,00	6,00	8,00	10,00	12,00	14,00	≥ 15,00
Component I: $t_{N,1}$ or $t_{N,2}$ in [mm]	$V_{R,k}$ in [kN]	0,50	1,29	1,29	1,29	1,29	1,29	1,29	1,29
		0,55	1,29	1,29	1,29	1,29	1,29	1,29	1,29
		0,63	2,35	2,35	2,35	1,69	1,69	1,69	1,69
		0,75	2,50	2,50	2,50	1,96	1,96	1,96	1,96
		0,88	2,50	2,50	2,50	1,96	1,96	1,96	1,96
		1,00	2,50	2,50	2,50	1,96	1,96	1,96	1,96
	$N_{R,k}$ in [kN]	0,50	4,23	4,23	4,23	4,23	4,23	4,23	4,23
		0,55	4,23	4,23	4,23	4,23	4,23	4,23	4,23
		0,63	5,82	5,82	5,82	5,82	5,82	5,82	5,82
		0,75	6,35	6,35	6,35	6,35	6,35	6,35	6,35
		0,88	6,35	6,35	6,35	6,35	6,35	6,35	6,35
		1,00	6,35	6,35	6,35	6,35	6,35	6,35	6,35
max. head displacement u depending on the sandwich panel thickness in [mm]	30	1	1	1	1	1	1	1	
	40	1	1	1	1	1	1	1	
	50	1	1	1	1	1	1	1	
	60	2,5	2,5	2,5	2,5	2,5	2,5	2,5	
	70	2,5	2,5	2,5	2,5	2,5	2,5	2,5	
	80	2,5	2,5	2,5	2,5	2,5	2,5	2,5	
	90	4	4	4	4	4	4	4	
	100	4	4	4	4	4	4	4	
	120	4	4	4	4	4	4	4	
	≥ 140	4	4	4	4	4	4	4	

Component I: S280GD, S320GD or S350GD – EN 10346

Component II: S235 – EN 10025-1 S280GD, S320GD or S350GD – EN 10346

Table 22.

Self-drilling screw GTR16SP A19 6,3/7,0 x L with hexagon head and aluminum sealing washer Ø19 mm									
Component II: t_{II} in [mm]		4,00	5,00	6,00	8,00	10,00	12,00	14,00	≥ 15,00
Component I: $t_{N,1}$ or $t_{N,2}$ in [mm]	$V_{R,k}$ in [kN]	0,50	1,29	1,29	1,29	1,29	1,29	1,29	1,29
		0,55	1,29	1,29	1,29	1,29	1,29	1,29	1,29
		0,63	2,35	2,35	2,35	2,35	2,35	2,35	2,35
		0,75	2,50	2,50	2,50	2,50	2,50	2,50	2,50
		0,88	2,50	2,50	2,50	2,50	2,50	2,50	2,50
		1,00	2,50	2,50	2,50	2,50	2,50	2,50	2,50
	$N_{R,k}$ in [kN]	0,50	3,65	3,65	3,65	3,65	3,65	3,65	3,65
		0,55	3,65	3,65	3,65	3,65	3,65	3,65	3,65
		0,63	4,60	4,60	4,60	4,60	4,60	4,60	4,60
		0,75	5,45	5,45	5,45	5,45	5,45	5,45	5,45
		0,88	5,45	5,45	5,45	5,45	5,45	5,45	5,45
		1,00	5,45	5,45	5,45	5,45	5,45	5,45	5,45
max. head displacement u depending on the sandwich panel thickness in [mm]	30	1	1	1	1	1	1	1	
	40	1	1	1	1	1	1	1	
	50	1	1	1	1	1	1	1	
	60	2,5	2,5	2,5	2,5	2,5	2,5	2,5	
	70	2,5	2,5	2,5	2,5	2,5	2,5	2,5	
	80	2,5	2,5	2,5	2,5	2,5	2,5	2,5	
	90	4	4	4	4	4	4	4	
	100	4	4	4	4	4	4	4	
	120	4	4	4	4	4	4	4	
	≥ 140	4	4	4	4	4	4	4	

Component I: S280GD, S320GD or S350GD – EN 10346

Component II: S235 – EN 10025-1 S280GD, S320GD or S350GD – EN 10346

Table 23.

Self-drilling screw GTR16SP A22 6,3/7,0 x L with hexagon head and aluminum sealing washer Ø22 mm									
Component II: t_{II} in [mm]		4,00	5,00	6,00	8,00	10,00	12,00	14,00	≥ 15,00
Component I: $t_{N,1}$ or $t_{N,2}$ in [mm]	$V_{R,k}$ in [kN]	0,50	1,29	1,29	1,29	1,29	1,29	1,29	1,29
		0,55	1,29	1,29	1,29	1,29	1,29	1,29	1,29
		0,63	2,35	2,35	2,35	2,35	2,35	2,35	2,35
		0,75	2,50	2,50	2,50	2,50	2,50	2,50	2,50
		0,88	2,50	2,50	2,50	2,50	2,50	2,50	2,50
		1,00	2,50	2,50	2,50	2,50	2,50	2,50	2,50
	$N_{R,k}$ in [kN]	0,50	3,65	3,65	3,65	3,65	3,65	3,65	3,65
		0,55	3,65	3,65	3,65	3,65	3,65	3,65	3,65
		0,63	4,60	4,60	4,60	4,60	4,60	4,60	4,60
		0,75	5,45	5,45	5,45	5,45	5,45	5,45	5,45
		0,88	5,45	5,45	5,45	5,45	5,45	5,45	5,45
		1,00	5,45	5,45	5,45	5,45	5,45	5,45	5,45
max. head displacement u depending on the sandwich panel thickness in [mm]	30	1	1	1	1	1	1	1	
	40	1	1	1	1	1	1	1	
	50	1	1	1	1	1	1	1	
	60	2,5	2,5	2,5	2,5	2,5	2,5	2,5	
	70	2,5	2,5	2,5	2,5	2,5	2,5	2,5	
	80	2,5	2,5	2,5	2,5	2,5	2,5	2,5	
	90	4	4	4	4	4	4	4	
	100	4	4	4	4	4	4	4	
	120	4	4	4	4	4	4	4	
	≥ 140	4	4	4	4	4	4	4	

Component I: S280GD, S320GD or S350GD – EN 10346

Component II: S235 – EN 10025-1 S280GD, S320GD or S350GD – EN 10346

Table 24.

Self-drilling screw GTR16SP A29 6,3/7,0 x L with hexagon head and aluminum sealing washer Ø29 mm									
Component II: t_{II} in [mm]		4,00	5,00	6,00	8,00	10,00	12,00	14,00	≥ 15,00
Component I: $t_{N,1}$ or $t_{N,2}$ in [mm]	$V_{R,k}$ in [kN]	0,50	1,29	1,29	1,29	1,29	1,29	1,29	1,29
		0,55	1,29	1,29	1,29	1,29	1,29	1,29	1,29
		0,63	2,35	2,35	2,35	2,35	2,35	2,35	2,35
		0,75	2,50	2,50	2,50	2,50	2,50	2,50	2,50
		0,88	2,50	2,50	2,50	2,50	2,50	2,50	2,50
		1,00	2,50	2,50	2,50	2,50	2,50	2,50	2,50
	$N_{R,k}$ in [kN]	0,50	3,65	3,65	3,65	3,65	3,65	3,65	3,65
		0,55	3,65	3,65	3,65	3,65	3,65	3,65	3,65
		0,63	4,60	4,60	4,60	4,60	4,60	4,60	4,60
		0,75	5,45	5,45	5,45	5,45	5,45	5,45	5,45
		0,88	5,45	5,45	5,45	5,45	5,45	5,45	5,45
		1,00	5,45	5,45	5,45	5,45	5,45	5,45	5,45
max. head displacement u depending on the sandwich panel thickness in [mm]	30	1	1	1	1	1	1	1	
	40	1	1	1	1	1	1	1	
	50	1	1	1	1	1	1	1	
	60	2,5	2,5	2,5	2,5	2,5	2,5	2,5	
	70	2,5	2,5	2,5	2,5	2,5	2,5	2,5	
	80	2,5	2,5	2,5	2,5	2,5	2,5	2,5	
	90	4	4	4	4	4	4	4	
	100	4	4	4	4	4	4	4	
	120	4	4	4	4	4	4	4	
	≥ 140	4	4	4	4	4	4	4	

Component I: S280GD, S320GD or S350GD – EN 10346

Component II: S235 – EN 10025-1 S280GD, S320GD or S350GD – EN 10346

Table 25.

Self-drilling screw GTR16SP S19 6,3/7,0 x L with hexagon head and stainless steel sealing washer $\varnothing 19$ mm									
Component II: t_{II} in [mm]		4,00	5,00	6,00	8,00	10,00	12,00	14,00	$\geq 15,00$
Component I: $t_{N,1}$ or $t_{N,2}$ in [mm]	$V_{R,k}$ in [kN]	0,50	1,29	1,29	1,29	1,29	1,29	1,29	1,29
		0,55	1,29	1,29	1,29	1,29	1,29	1,29	1,29
		0,63	2,35	2,35	2,35	2,35	2,35	2,35	2,35
		0,75	2,50	2,50	2,50	2,50	2,50	2,50	2,50
		0,88	2,50	2,50	2,50	2,50	2,50	2,50	2,50
		1,00	2,50	2,50	2,50	2,50	2,50	2,50	2,50
	$N_{R,k}$ in [kN]	0,50	3,65	3,65	3,65	3,65	3,65	3,65	3,65
		0,55	3,65	3,65	3,65	3,65	3,65	3,65	3,65
		0,63	4,60	4,60	4,60	4,60	4,60	4,60	4,60
		0,75	5,45	5,45	5,45	5,45	5,45	5,45	5,45
		0,88	5,45	5,45	5,45	5,45	5,45	5,45	5,45
		1,00	5,45	5,45	5,45	5,45	5,45	5,45	5,45
max. head displacement u depending on the sandwich panel thickness in [mm]	30	1	1	1	1	1	1	1	
	40	1	1	1	1	1	1	1	
	50	1	1	1	1	1	1	1	
	60	2,5	2,5	2,5	2,5	2,5	2,5	2,5	
	70	2,5	2,5	2,5	2,5	2,5	2,5	2,5	
	80	2,5	2,5	2,5	2,5	2,5	2,5	2,5	
	90	4	4	4	4	4	4	4	
	100	4	4	4	4	4	4	4	
	120	4	4	4	4	4	4	4	
	≥ 140	4	4	4	4	4	4	4	

Component I: S280GD, S320GD or S350GD – EN 10346

Component II: S235 – EN 10025-1 S280GD, S320GD or S350GD – EN 10346

Table 26.

Self-drilling screw GTR16SP S22 6,3/7,0 x L with hexagon head and stainless steel sealing washer $\varnothing 22$ mm										
Component II: t_{II} in [mm]		4,00	5,00	6,00	8,00	10,00	12,00	14,00	$\geq 15,00$	
Component I: $t_{N,1}$ or $t_{N,2}$ in [mm]	$V_{R,k}$ in [kN]	0,50	1,29	1,29	1,29	1,29	1,29	1,29	1,29	1,29
		0,55	1,29	1,29	1,29	1,29	1,29	1,29	1,29	1,29
		0,63	2,35	2,35	2,35	2,35	2,35	2,35	2,35	2,35
		0,75	2,50	2,50	2,50	2,50	2,50	2,50	2,50	2,50
		0,88	2,50	2,50	2,50	2,50	2,50	2,50	2,50	2,50
		1,00	2,50	2,50	2,50	2,50	2,50	2,50	2,50	2,50
	$N_{R,k}$ in [kN]	0,50	3,65	3,65	3,65	3,65	3,65	3,65	3,65	3,65
		0,55	3,65	3,65	3,65	3,65	3,65	3,65	3,65	3,65
		0,63	4,60	4,60	4,60	4,60	4,60	4,60	4,60	4,60
		0,75	5,45	5,45	5,45	5,45	5,45	5,45	5,45	5,45
		0,88	5,45	5,45	5,45	5,45	5,45	5,45	5,45	5,45
		1,00	5,45	5,45	5,45	5,45	5,45	5,45	5,45	5,45
max. head displacement u depending on the sandwich panel thickness in [mm]	30	1	1	1	1	1	1	1	1	
	40	1	1	1	1	1	1	1	1	
	50	1	1	1	1	1	1	1	1	
	60	2,5	2,5	2,5	2,5	2,5	2,5	2,5	2,5	
	70	2,5	2,5	2,5	2,5	2,5	2,5	2,5	2,5	
	80	2,5	2,5	2,5	2,5	2,5	2,5	2,5	2,5	
	90	4	4	4	4	4	4	4	4	
	100	4	4	4	4	4	4	4	4	
	120	4	4	4	4	4	4	4	4	
	≥ 140	4	4	4	4	4	4	4	4	

Component I: S280GD, S320GD or S350GD – EN 10346

Component II: S235 – EN 10025-1 S280GD, S320GD or S350GD – EN 10346

Table 27.

Self-drilling screw GTR16SP S29 6,3/7,0 x L with hexagon head and stainless steel sealing washer $\varnothing 29$ mm										
Component II: t_{II} in [mm]		4,00	5,00	6,00	8,00	10,00	12,00	14,00	$\geq 15,00$	
Component I: $t_{N,1}$ or $t_{N,2}$ in [mm]	$V_{R,k}$ in [kN]	0,50	1,29	1,29	1,29	1,29	1,29	1,29	1,29	1,29
		0,55	1,29	1,29	1,29	1,29	1,29	1,29	1,29	1,29
		0,63	2,35	2,35	2,35	2,35	2,35	2,35	2,35	2,35
		0,75	2,50	2,50	2,50	2,50	2,50	2,50	2,50	2,50
		0,88	2,50	2,50	2,50	2,50	2,50	2,50	2,50	2,50
		1,00	2,50	2,50	2,50	2,50	2,50	2,50	2,50	2,50
	$N_{R,k}$ in [kN]	0,50	3,65	3,65	3,65	3,65	3,65	3,65	3,65	3,65
		0,55	3,65	3,65	3,65	3,65	3,65	3,65	3,65	3,65
		0,63	4,60	4,60	4,60	4,60	4,60	4,60	4,60	4,60
		0,75	5,45	5,45	5,45	5,45	5,45	5,45	5,45	5,45
		0,88	5,45	5,45	5,45	5,45	5,45	5,45	5,45	5,45
		1,00	5,45	5,45	5,45	5,45	5,45	5,45	5,45	5,45
max. head displacement u depending on the sandwich panel thickness in [mm]	30	1	1	1	1	1	1	1	1	
	40	1	1	1	1	1	1	1	1	
	50	1	1	1	1	1	1	1	1	
	60	2,5	2,5	2,5	2,5	2,5	2,5	2,5	2,5	
	70	2,5	2,5	2,5	2,5	2,5	2,5	2,5	2,5	
	80	2,5	2,5	2,5	2,5	2,5	2,5	2,5	2,5	
	90	4	4	4	4	4	4	4	4	
	100	4	4	4	4	4	4	4	4	
	120	4	4	4	4	4	4	4	4	
	≥ 140	4	4	4	4	4	4	4	4	

Component I: S280GD, S320GD or S350GD – EN 10346

Component II: S235 – EN 10025-1 S280GD, S320GD or S350GD – EN 10346

Table 28.

		Self-drilling screw GT20SP Z19 6,3/7,0 x L with hexagon head and carbon steel sealing washer $\geq \varnothing 19$ mm							
Component II: t_{II} in [mm]		4,00	5,00	6,00	8,00	10,00	12,00	14,00	$\geq 15,00$
Component I: $t_{N,1}$ or $t_{N,2}$ in [mm]	$V_{R,k}$ in [kN]	0,50	1,29	1,29	1,29	1,29	1,29	1,29	1,29
		0,55	1,29	1,29	1,29	1,29	1,29	1,29	1,29
		0,63	2,35	2,35	2,35	2,35	2,35	2,35	2,35
		0,75	2,50	2,50	2,50	2,50	2,50	2,50	2,50
		0,88	2,50	2,50	2,50	2,50	2,50	2,50	2,50
		1,00	2,50	2,50	2,50	2,50	2,50	2,50	2,50
	$N_{R,k}$ in [kN]	0,50	3,65	3,65	3,65	3,65	3,65	3,65	3,65
		0,55	3,65	3,65	3,65	3,65	3,65	3,65	3,65
		0,63	4,60	4,60	4,60	4,60	4,60	4,60	4,60
		0,75	5,45	5,45	5,45	5,45	5,45	5,45	5,45
		0,88	5,45	5,45	5,45	5,45	5,45	5,45	5,45
		1,00	5,45	5,45	5,45	5,45	5,45	5,45	5,45
max. head displacement u depending on the sandwich panel thickness in [mm]	30	1	1	1	1	1	1	1	
	40	1	1	1	1	1	1	1	
	50	1	1	1	1	1	1	1	
	60	2,5	2,5	2,5	2,5	2,5	2,5	2,5	
	70	2,5	2,5	2,5	2,5	2,5	2,5	2,5	
	80	2,5	2,5	2,5	2,5	2,5	2,5	2,5	
	90	4	4	4	4	4	4	4	
	100	4	4	4	4	4	4	4	
	120	4	4	4	4	4	4	4	
	≥ 140	4	4	4	4	4	4	4	

Component I: S280GD, S320GD or S350GD – EN 10346

Component II: S235 – EN 10025-1 S280GD, S320GD or S350GD – EN 10346

Table 29.

Self-drilling screw GT20SP Z22 6,3/7,0 x L with hexagon head and carbon steel sealing washer $\geq \text{Ø}22$ mm									
Component II: t_{II} in [mm]		4,00	5,00	6,00	8,00	10,00	12,00	14,00	$\geq 15,00$
Component I: $t_{N,1}$ or $t_{N,2}$ in [mm]	$V_{R,k}$ in [kN]	0,50	1,29	1,29	1,29	1,29	1,29	1,29	1,29
		0,55	1,29	1,29	1,29	1,29	1,29	1,29	1,29
		0,63	2,35	2,35	2,35	1,69	1,69	1,69	1,69
		0,75	2,50	2,50	2,50	1,96	1,96	1,96	1,96
		0,88	2,50	2,50	2,50	1,96	1,96	1,96	1,96
		1,00	2,50	2,50	2,50	1,96	1,96	1,96	1,96
	$N_{R,k}$ in [kN]	0,50	3,65	3,65	3,65	3,43	3,43	3,43	3,43
		0,55	3,65	3,65	3,65	3,43	3,43	3,43	3,43
		0,63	4,60	4,60	4,60	4,32	4,32	4,32	4,32
		0,75	5,45	5,45	5,45	6,10	6,10	6,10	6,10
		0,88	5,45	5,45	5,45	6,10	6,10	6,10	6,10
		1,00	5,45	5,45	5,45	6,10	6,10	6,10	6,10
max. head displacement u depending on the sandwich panel thickness in [mm]	30	1	1	1	1	1	1	1	
	40	1	1	1	1	1	1	1	
	50	1	1	1	1	1	1	1	
	60	2,5	2,5	2,5	2,5	2,5	2,5	2,5	
	70	2,5	2,5	2,5	2,5	2,5	2,5	2,5	
	80	2,5	2,5	2,5	2,5	2,5	2,5	2,5	
	90	4	4	4	4	4	4	4	
	100	4	4	4	4	4	4	4	
	120	4	4	4	4	4	4	4	
	≥ 140	4	4	4	4	4	4	4	

Component I: S280GD, S320GD or S350GD – EN 10346

Component II: S235 – EN 10025-1 S280GD, S320GD or S350GD – EN 10346

Table 30.

Self-drilling screw GT20SP Z29 6,3/7,0 x L with hexagon head and carbon steel sealing washer $\geq \text{Ø}29 \text{ mm}$										
Component II: t_{II} in [mm]		4,00	5,00	6,00	8,00	10,00	12,00	14,00	$\geq 15,00$	
Component I: $t_{N,1}$ or $t_{N,2}$ in [mm]	$V_{R,k}$ in [kN]	0,50	1,29	1,29	1,29	1,29	1,29	1,29	1,29	1,29
		0,55	1,29	1,29	1,29	1,29	1,29	1,29	1,29	1,29
		0,63	2,35	2,35	2,35	1,69	1,69	1,69	1,69	1,69
		0,75	2,50	2,50	2,50	1,96	1,96	1,96	1,96	1,96
		0,88	2,50	2,50	2,50	1,96	1,96	1,96	1,96	1,96
		1,00	2,50	2,50	2,50	1,96	1,96	1,96	1,96	1,96
	$N_{R,k}$ in [kN]	0,50	4,23	4,23	4,23	4,23	4,23	4,23	4,23	4,23
		0,55	4,23	4,23	4,23	4,23	4,23	4,23	4,23	4,23
		0,63	5,82	5,82	5,82	5,82	5,82	5,82	5,82	5,82
		0,75	6,35	6,35	6,35	6,35	6,35	6,35	6,35	6,35
		0,88	6,35	6,35	6,35	6,35	6,35	6,35	6,35	6,35
		1,00	6,35	6,35	6,35	6,35	6,35	6,35	6,35	6,35
max. head displacement u depending on the sandwich panel thickness in [mm]	30	1	1	1	1	1	1	1	1	
	40	1	1	1	1	1	1	1	1	
	50	1	1	1	1	1	1	1	1	
	60	2,5	2,5	2,5	2,5	2,5	2,5	2,5	2,5	
	70	2,5	2,5	2,5	2,5	2,5	2,5	2,5	2,5	
	80	2,5	2,5	2,5	2,5	2,5	2,5	2,5	2,5	
	90	4	4	4	4	4	4	4	4	
	100	4	4	4	4	4	4	4	4	
	120	4	4	4	4	4	4	4	4	
	≥ 140	4	4	4	4	4	4	4	4	

Component I: S280GD, S320GD or S350GD – EN 10346

Component II: S235 – EN 10025-1 S280GD, S320GD or S350GD – EN 10346

Table 31.

Self-drilling screw GTR20SP A19 6,3/7,0 x L with hexagon head and aluminum sealing washer $\geq \varnothing 19$ mm									
Component II: t_{II} in [mm]		4,00	5,00	6,00	8,00	10,00	12,00	14,00	$\geq 15,00$
Component I: $t_{N,1}$ or $t_{N,2}$ in [mm]	$V_{R,k}$ in [kN]	0,50	1,29	1,29	1,29	1,29	1,29	1,29	1,29
		0,55	1,29	1,29	1,29	1,29	1,29	1,29	1,29
		0,63	2,35	2,35	2,35	2,35	2,35	2,35	2,35
		0,75	2,50	2,50	2,50	2,50	2,50	2,50	2,50
		0,88	2,50	2,50	2,50	2,50	2,50	2,50	2,50
		1,00	2,50	2,50	2,50	2,50	2,50	2,50	2,50
	$N_{R,k}$ in [kN]	0,50	3,65	3,65	3,65	3,65	3,65	3,65	3,65
		0,55	3,65	3,65	3,65	3,65	3,65	3,65	3,65
		0,63	4,60	4,60	4,60	4,60	4,60	4,60	4,60
		0,75	5,45	5,45	5,45	5,45	5,45	5,45	5,45
		0,88	5,45	5,45	5,45	5,45	5,45	5,45	5,45
		1,00	5,45	5,45	5,45	5,45	5,45	5,45	5,45
max. head displacement u depending on the sandwich panel thickness in [mm]	30	1	1	1	1	1	1	1	
	40	1	1	1	1	1	1	1	
	50	1	1	1	1	1	1	1	
	60	2,5	2,5	2,5	2,5	2,5	2,5	2,5	
	70	2,5	2,5	2,5	2,5	2,5	2,5	2,5	
	80	2,5	2,5	2,5	2,5	2,5	2,5	2,5	
	90	4	4	4	4	4	4	4	
	100	4	4	4	4	4	4	4	
	120	4	4	4	4	4	4	4	
	≥ 140	4	4	4	4	4	4	4	

Component I: S280GD, S320GD or S350GD – EN 10346

Component II: S235 – EN 10025-1 S280GD, S320GD or S350GD – EN 10346

Table 32.

Self-drilling screw GTR20SP A22 6,3/7,0 x L with hexagon head and aluminum sealing washer $\geq \varnothing 22$ mm										
Component II: t_{II} in [mm]		4,00	5,00	6,00	8,00	10,00	12,00	14,00	$\geq 15,00$	
Component I: $t_{N,1}$ or $t_{N,2}$ in [mm]	$V_{R,k}$ in [kN]	0,50	1,29	1,29	1,29	1,29	1,29	1,29	1,29	1,29
		0,55	1,29	1,29	1,29	1,29	1,29	1,29	1,29	1,29
		0,63	2,35	2,35	2,35	2,35	2,35	2,35	2,35	2,35
		0,75	2,50	2,50	2,50	2,50	2,50	2,50	2,50	2,50
		0,88	2,50	2,50	2,50	2,50	2,50	2,50	2,50	2,50
		1,00	2,50	2,50	2,50	2,50	2,50	2,50	2,50	2,50
	$N_{R,k}$ in [kN]	0,50	3,65	3,65	3,65	3,65	3,65	3,65	3,65	3,65
		0,55	3,65	3,65	3,65	3,65	3,65	3,65	3,65	3,65
		0,63	4,60	4,60	4,60	4,60	4,60	4,60	4,60	4,60
		0,75	5,45	5,45	5,45	5,45	5,45	5,45	5,45	5,45
		0,88	5,45	5,45	5,45	5,45	5,45	5,45	5,45	5,45
		1,00	5,45	5,45	5,45	5,45	5,45	5,45	5,45	5,45
max. head displacement u depending on the sandwich panel thickness in [mm]	30	1	1	1	1	1	1	1	1	
	40	1	1	1	1	1	1	1	1	
	50	1	1	1	1	1	1	1	1	
	60	2,5	2,5	2,5	2,5	2,5	2,5	2,5	2,5	
	70	2,5	2,5	2,5	2,5	2,5	2,5	2,5	2,5	
	80	2,5	2,5	2,5	2,5	2,5	2,5	2,5	2,5	
	90	4	4	4	4	4	4	4	4	
	100	4	4	4	4	4	4	4	4	
	120	4	4	4	4	4	4	4	4	
	≥ 140	4	4	4	4	4	4	4	4	

Component I: S280GD, S320GD or S350GD – EN 10346

Component II: S235 – EN 10025-1 S280GD, S320GD or S350GD – EN 10346

Table 33.

Self-drilling screw GTR20SP A29 6,3/7,0 x L with hexagon head and aluminum sealing washer $\geq \varnothing 29$ mm									
Component II: t_{II} in [mm]		4,00	5,00	6,00	8,00	10,00	12,00	14,00	$\geq 15,00$
Component I: $t_{N,1}$ or $t_{N,2}$ in [mm]	$V_{R,k}$ in [kN]	0,50	1,29	1,29	1,29	1,29	1,29	1,29	1,29
		0,55	1,29	1,29	1,29	1,29	1,29	1,29	1,29
		0,63	2,35	2,35	2,35	2,35	2,35	2,35	2,35
		0,75	2,50	2,50	2,50	2,50	2,50	2,50	2,50
		0,88	2,50	2,50	2,50	2,50	2,50	2,50	2,50
		1,00	2,50	2,50	2,50	2,50	2,50	2,50	2,50
	$N_{R,k}$ in [kN]	0,50	3,65	3,65	3,65	3,65	3,65	3,65	3,65
		0,55	3,65	3,65	3,65	3,65	3,65	3,65	3,65
		0,63	4,60	4,60	4,60	4,60	4,60	4,60	4,60
		0,75	5,45	5,45	5,45	5,45	5,45	5,45	5,45
		0,88	5,45	5,45	5,45	5,45	5,45	5,45	5,45
		1,00	5,45	5,45	5,45	5,45	5,45	5,45	5,45
max. head displacement u depending on the sandwich panel thickness in [mm]	30	1	1	1	1	1	1	1	
	40	1	1	1	1	1	1	1	
	50	1	1	1	1	1	1	1	
	60	2,5	2,5	2,5	2,5	2,5	2,5	2,5	
	70	2,5	2,5	2,5	2,5	2,5	2,5	2,5	
	80	2,5	2,5	2,5	2,5	2,5	2,5	2,5	
	90	4	4	4	4	4	4	4	
	100	4	4	4	4	4	4	4	
	120	4	4	4	4	4	4	4	
	≥ 140	4	4	4	4	4	4	4	

Component I: S280GD, S320GD or S350GD – EN 10346

Component II: S235 – EN 10025-1 S280GD, S320GD or S350GD – EN 10346

Table 34.

Self-drilling screw GTR20SP S19 6,3/7,0 x L with hexagon head and stainless steel sealing washer $\geq \varnothing 19$ mm										
Component II: t_{II} in [mm]		4,00	5,00	6,00	8,00	10,00	12,00	14,00	$\geq 15,00$	
Component I: $t_{N,1}$ or $t_{N,2}$ in [mm]	$V_{R,k}$ in [kN]	0,50	1,29	1,29	1,29	1,29	1,29	1,29	1,29	1,29
		0,55	1,29	1,29	1,29	1,29	1,29	1,29	1,29	1,29
		0,63	2,35	2,35	2,35	2,35	2,35	2,35	2,35	2,35
		0,75	2,50	2,50	2,50	2,50	2,50	2,50	2,50	2,50
		0,88	2,50	2,50	2,50	2,50	2,50	2,50	2,50	2,50
		1,00	2,50	2,50	2,50	2,50	2,50	2,50	2,50	2,50
	$N_{R,k}$ in [kN]	0,50	3,65	3,65	3,65	3,65	3,65	3,65	3,65	3,65
		0,55	3,65	3,65	3,65	3,65	3,65	3,65	3,65	3,65
		0,63	4,60	4,60	4,60	4,60	4,60	4,60	4,60	4,60
		0,75	5,45	5,45	5,45	5,45	5,45	5,45	5,45	5,45
		0,88	5,45	5,45	5,45	5,45	5,45	5,45	5,45	5,45
		1,00	5,45	5,45	5,45	5,45	5,45	5,45	5,45	5,45
max. head displacement u depending on the sandwich panel thickness in [mm]	30	1	1	1	1	1	1	1	1	
	40	1	1	1	1	1	1	1	1	
	50	1	1	1	1	1	1	1	1	
	60	2,5	2,5	2,5	2,5	2,5	2,5	2,5	2,5	
	70	2,5	2,5	2,5	2,5	2,5	2,5	2,5	2,5	
	80	2,5	2,5	2,5	2,5	2,5	2,5	2,5	2,5	
	90	4	4	4	4	4	4	4	4	
	100	4	4	4	4	4	4	4	4	
	120	4	4	4	4	4	4	4	4	
	≥ 140	4	4	4	4	4	4	4	4	

Component I: S280GD, S320GD or S350GD – EN 10346

Component II: S235 – EN 10025-1 S280GD, S320GD or S350GD – EN 10346

Table 35.

Self-drilling screw GTR20SP S22 6,3/7,0 x L with hexagon head and stainless steel sealing washer $\geq \varnothing 22$ mm									
Component II: t_{II} in [mm]		4,00	5,00	6,00	8,00	10,00	12,00	14,00	$\geq 15,00$
Component I: $t_{N,1}$ or $t_{N,2}$ in [mm]	$V_{R,k}$ in [kN]	0,50	1,29	1,29	1,29	1,29	1,29	1,29	1,29
		0,55	1,29	1,29	1,29	1,29	1,29	1,29	1,29
		0,63	2,35	2,35	2,35	2,35	2,35	2,35	2,35
		0,75	2,50	2,50	2,50	2,50	2,50	2,50	2,50
		0,88	2,50	2,50	2,50	2,50	2,50	2,50	2,50
		1,00	2,50	2,50	2,50	2,50	2,50	2,50	2,50
	$N_{R,k}$ in [kN]	0,50	3,65	3,65	3,65	3,65	3,65	3,65	3,65
		0,55	3,65	3,65	3,65	3,65	3,65	3,65	3,65
		0,63	4,60	4,60	4,60	4,60	4,60	4,60	4,60
		0,75	5,45	5,45	5,45	5,45	5,45	5,45	5,45
		0,88	5,45	5,45	5,45	5,45	5,45	5,45	5,45
		1,00	5,45	5,45	5,45	5,45	5,45	5,45	5,45
max. head displacement u depending on the sandwich panel thickness in [mm]	30	1	1	1	1	1	1	1	
	40	1	1	1	1	1	1	1	
	50	1	1	1	1	1	1	1	
	60	2,5	2,5	2,5	2,5	2,5	2,5	2,5	
	70	2,5	2,5	2,5	2,5	2,5	2,5	2,5	
	80	2,5	2,5	2,5	2,5	2,5	2,5	2,5	
	90	4	4	4	4	4	4	4	
	100	4	4	4	4	4	4	4	
	120	4	4	4	4	4	4	4	
	≥ 140	4	4	4	4	4	4	4	

Component I: S280GD, S320GD or S350GD – EN 10346

Component II: S235 – EN 10025-1 S280GD, S320GD or S350GD – EN 10346

Table 36.

Self-drilling screw GTR20SP S29 6,3/7,0 x L with hexagon head and stainless steel sealing washer $\geq \varnothing 29$ mm										
Component II: t_{II} in [mm]		4,00	5,00	6,00	8,00	10,00	12,00	14,00	$\geq 15,00$	
Component I: $t_{N,1}$ or $t_{N,2}$ in [mm]	$V_{R,k}$ in [kN]	0,50	1,29	1,29	1,29	1,29	1,29	1,29	1,29	1,29
		0,55	1,29	1,29	1,29	1,29	1,29	1,29	1,29	1,29
		0,63	2,35	2,35	2,35	2,35	2,35	2,35	2,35	2,35
		0,75	2,50	2,50	2,50	2,50	2,50	2,50	2,50	2,50
		0,88	2,50	2,50	2,50	2,50	2,50	2,50	2,50	2,50
		1,00	2,50	2,50	2,50	2,50	2,50	2,50	2,50	2,50
	$N_{R,k}$ in [kN]	0,50	3,65	3,65	3,65	3,65	3,65	3,65	3,65	3,65
		0,55	3,65	3,65	3,65	3,65	3,65	3,65	3,65	3,65
		0,63	4,60	4,60	4,60	4,60	4,60	4,60	4,60	4,60
		0,75	5,45	5,45	5,45	5,45	5,45	5,45	5,45	5,45
		0,88	5,45	5,45	5,45	5,45	5,45	5,45	5,45	5,45
		1,00	5,45	5,45	5,45	5,45	5,45	5,45	5,45	5,45
max. head displacement u depending on the sandwich panel thickness in [mm]	30	1	1	1	1	1	1	1	1	
	40	1	1	1	1	1	1	1	1	
	50	1	1	1	1	1	1	1	1	
	60	2,5	2,5	2,5	2,5	2,5	2,5	2,5	2,5	
	70	2,5	2,5	2,5	2,5	2,5	2,5	2,5	2,5	
	80	2,5	2,5	2,5	2,5	2,5	2,5	2,5	2,5	
	90	4	4	4	4	4	4	4	4	
	100	4	4	4	4	4	4	4	4	
	120	4	4	4	4	4	4	4	4	
	≥ 140	4	4	4	4	4	4	4	4	

Component I: S280GD, S320GD or S350GD – EN 10346

Component II: S235 – EN 10025-1 S280GD, S320GD or S350GD – EN 10346

Table 37.

		Self-drilling screw GT25SP Z19 6,3/7,0 x L with hexagon head and carbon steel sealing washer Ø19 mm							
Component II: t_{II} in [mm]		4,00	5,00	6,00	8,00	10,00	12,00	14,00	≥ 15,00
Component I: $t_{N,1}$ or $t_{N,2}$ in [mm]	$V_{R,k}$ in [kN]	0,50	1,29	1,29	1,29	1,29	1,29	1,29	1,29
		0,55	1,29	1,29	1,29	1,29	1,29	1,29	1,29
		0,63	2,35	2,35	2,35	2,35	2,35	2,35	2,35
		0,75	2,50	2,50	2,50	2,50	2,50	2,50	2,50
		0,88	2,50	2,50	2,50	2,50	2,50	2,50	2,50
		1,00	2,50	2,50	2,50	2,50	2,50	2,50	2,50
	$N_{R,k}$ in [kN]	0,50	3,65	3,65	3,65	3,65	3,65	3,65	3,65
		0,55	3,65	3,65	3,65	3,65	3,65	3,65	3,65
		0,63	4,60	4,60	4,60	4,60	4,60	4,60	4,60
		0,75	5,45	5,45	5,45	5,45	5,45	5,45	5,45
		0,88	5,45	5,45	5,45	5,45	5,45	5,45	5,45
		1,00	5,45	5,45	5,45	5,45	5,45	5,45	5,45
max. head displacement u depending on the sandwich panel thickness in [mm]	30	1	1	1	1	1	1	1	
	40	1	1	1	1	1	1	1	
	50	1	1	1	1	1	1	1	
	60	2,5	2,5	2,5	2,5	2,5	2,5	2,5	
	70	2,5	2,5	2,5	2,5	2,5	2,5	2,5	
	80	2,5	2,5	2,5	2,5	2,5	2,5	2,5	
	90	4	4	4	4	4	4	4	
	100	4	4	4	4	4	4	4	
	120	4	4	4	4	4	4	4	
	≥ 140	4	4	4	4	4	4	4	

Component I: S280GD, S320GD or S350GD – EN 10346

Component II: S235 – EN 10025-1 S280GD, S320GD or S350GD – EN 10346

Table 38.

Self-drilling screw GT25SP Z22 6,3/7,0 x L with hexagon head and carbon steel sealing washer Ø22 mm									
Component II: t_{II} in [mm]		4,00	5,00	6,00	8,00	10,00	12,00	14,00	15,00
Component I: $t_{N,1}$ or $t_{N,2}$ in [mm]	$V_{R,k}$ in [kN]	0,50	1,29	1,29	1,29	1,29	1,29	1,29	1,29
		0,55	1,29	1,29	1,29	1,29	1,29	1,29	1,29
		0,63	2,35	2,35	2,35	1,69	1,69	1,69	1,69
		0,75	2,50	2,50	2,50	1,96	1,96	1,96	1,96
		0,88	2,50	2,50	2,50	1,96	1,96	1,96	1,96
		1,00	2,50	2,50	2,50	1,96	1,96	1,96	1,96
	$N_{R,k}$ in [kN]	0,50	3,65	3,65	3,65	3,65	3,65	3,65	3,65
		0,55	3,65	3,65	3,65	3,65	3,65	3,65	3,65
		0,63	4,60	4,60	4,60	4,60	4,60	4,60	4,60
		0,75	5,45	5,45	5,45	5,45	5,45	5,45	5,45
		0,88	5,45	5,45	5,45	5,45	5,45	5,45	5,45
		1,00	5,45	5,45	5,45	5,45	5,45	5,45	5,45
max. head displacement u depending on the sandwich panel thickness in [mm]	30	1	1	1	1	1	1	1	
	40	1	1	1	1	1	1	1	
	50	1	1	1	1	1	1	1	
	60	2,5	2,5	2,5	2,5	2,5	2,5	2,5	
	70	2,5	2,5	2,5	2,5	2,5	2,5	2,5	
	80	2,5	2,5	2,5	2,5	2,5	2,5	2,5	
	90	4	4	4	4	4	4	4	
	100	4	4	4	4	4	4	4	
	120	4	4	4	4	4	4	4	
	≥ 140	4	4	4	4	4	4	4	

Component I: S280GD, S320GD or S350GD – EN 10346

Component II: S235 – EN 10025-1 S280GD, S320GD or S350GD – EN 10346

Table 39.

Self-drilling screw GT25SP Z29 6,3/7,0 x L with hexagon head and carbon steel sealing washer Ø29 mm									
Component II: t_{II} in [mm]		4,00	5,00	6,00	8,00	10,00	12,00	14,00	15,00
Component I: $t_{N,1}$ or $t_{N,2}$ in [mm]	$V_{R,k}$ in [kN]	0,50	1,29	1,29	1,29	1,29	1,29	1,29	1,29
		0,55	1,29	1,29	1,29	1,29	1,29	1,29	1,29
		0,63	2,35	2,35	2,35	1,69	1,69	1,69	1,69
		0,75	2,50	2,50	2,50	1,96	1,96	1,96	1,96
		0,88	2,50	2,50	2,50	1,96	1,96	1,96	1,96
		1,00	2,50	2,50	2,50	1,96	1,96	1,96	1,96
	$N_{R,k}$ in [kN]	0,50	4,23	4,23	4,23	4,23	4,23	4,23	4,23
		0,55	4,23	4,23	4,23	4,23	4,23	4,23	4,23
		0,63	5,82	5,82	5,82	5,82	5,82	5,82	5,82
		0,75	6,35	6,35	6,35	6,35	6,35	6,35	6,35
		0,88	6,35	6,35	6,35	6,35	6,35	6,35	6,35
		1,00	6,35	6,35	6,35	6,35	6,35	6,35	6,35
max. head displacement u depending on the sandwich panel thickness in [mm]	30	1	1	1	1	1	1	1	
	40	1	1	1	1	1	1	1	
	50	1	1	1	1	1	1	1	
	60	2,5	2,5	2,5	2,5	2,5	2,5	2,5	
	70	2,5	2,5	2,5	2,5	2,5	2,5	2,5	
	80	2,5	2,5	2,5	2,5	2,5	2,5	2,5	
	90	4	4	4	4	4	4	4	
	100	4	4	4	4	4	4	4	
	120	4	4	4	4	4	4	4	
	≥ 140	4	4	4	4	4	4	4	

Component I: S280GD, S320GD or S350GD – EN 10346

Component II: S235 – EN 10025-1 S280GD, S320GD or S350GD – EN 10346

Table 40.

Self-drilling screw GTR25SP A19 6,3/7,0 x L with hexagon head and aluminum sealing washer Ø19 mm								
Component II: t_{II} in [mm]		4,00	5,00	6,00	7,00	8,00	9,00	≥ 10,00
Component I: $t_{N,1}$ or $t_{N,2}$ in [mm]	$V_{R,k}$ in [kN]	0,50	1,29	1,29	1,29	1,29	1,29	1,29
		0,55	1,29	1,29	1,29	1,29	1,29	1,29
		0,63	2,35	2,35	2,35	2,35	2,35	2,35
		0,75	2,50	2,50	2,50	2,50	2,50	2,50
		0,88	2,50	2,50	2,50	2,50	2,50	2,50
		1,00	2,50	2,50	2,50	2,50	2,50	2,50
	$N_{R,k}$ in [kN]	0,50	3,65	3,65	3,65	3,65	3,65	3,65
		0,55	3,65	3,65	3,65	3,65	3,65	3,65
		0,63	4,60	4,60	4,60	4,60	4,60	4,60
		0,75	5,45	5,45	5,45	5,45	5,45	5,45
		0,88	5,45	5,45	5,45	5,45	5,45	5,45
		1,00	5,45	5,45	5,45	5,45	5,45	5,45
max. head displacement u depending on the sandwich panel thickness in [mm]	30	1	1	1	1	1	1	
	40	1	1	1	1	1	1	
	50	1	1	1	1	1	1	
	60	2,5	2,5	2,5	2,5	2,5	2,5	
	70	2,5	2,5	2,5	2,5	2,5	2,5	
	80	2,5	2,5	2,5	2,5	2,5	2,5	
	90	4	4	4	4	4	4	
	100	4	4	4	4	4	4	
	120	4	4	4	4	4	4	
	≥ 140	4	4	4	4	4	4	

Component I: S280GD, S320GD or S350GD – EN 10346

Component II: S235 – EN 10025-1 S280GD, S320GD or S350GD – EN 10346

Table 41.

Self-drilling screw GTR25SP A22 6,3/7,0 x L with hexagon head and aluminum sealing washer Ø22 mm									
Component II: t_{II} in [mm]		4,00	5,00	6,00	7,00	8,00	9,00	≥ 10,00	
Component I: $t_{N,1}$ or $t_{N,2}$ in [mm]	$V_{R,k}$ in [kN]	0,50	1,29	1,29	1,29	1,29	1,29	1,29	1,29
		0,55	1,29	1,29	1,29	1,29	1,29	1,29	1,29
		0,63	2,35	2,35	2,35	2,35	2,35	2,35	2,35
		0,75	2,50	2,50	2,50	2,50	2,50	2,50	2,50
		0,88	2,50	2,50	2,50	2,50	2,50	2,50	2,50
		1,00	2,50	2,50	2,50	2,50	2,50	2,50	2,50
	$N_{R,k}$ in [kN]	0,50	3,65	3,65	3,65	3,65	3,65	3,65	3,65
		0,55	3,65	3,65	3,65	3,65	3,65	3,65	3,65
		0,63	4,60	4,60	4,60	4,60	4,60	4,60	4,60
		0,75	5,45	5,45	5,45	5,45	5,45	5,45	5,45
		0,88	5,45	5,45	5,45	5,45	5,45	5,45	5,45
		1,00	5,45	5,45	5,45	5,45	5,45	5,45	5,45
max. head displacement u depending on the sandwich panel thickness in [mm]	30	1	1	1	1	1	1	1	
	40	1	1	1	1	1	1	1	
	50	1	1	1	1	1	1	1	
	60	2,5	2,5	2,5	2,5	2,5	2,5	2,5	
	70	2,5	2,5	2,5	2,5	2,5	2,5	2,5	
	80	2,5	2,5	2,5	2,5	2,5	2,5	2,5	
	90	4	4	4	4	4	4	4	
	100	4	4	4	4	4	4	4	
	120	4	4	4	4	4	4	4	
	≥ 140	4	4	4	4	4	4	4	

Component I: S280GD, S320GD or S350GD – EN 10346

Component II: S235 – EN 10025-1 S280GD, S320GD or S350GD – EN 10346

Table 42.

Self-drilling screw GTR25SP A29 6,3/7,0 x L with hexagon head and aluminum sealing washer $\varnothing 29$ mm										
Component II: t_{II} in [mm]		4,00	5,00	6,00	8,00	10,00	12,00	14,00	$\geq 15,00$	
Component I: $t_{N,1}$ or $t_{N,2}$ in [mm]	$V_{R,k}$ in [kN]	0,50	1,29	1,29	1,29	1,29	1,29	1,29	1,29	1,29
		0,55	1,29	1,29	1,29	1,29	1,29	1,29	1,29	1,29
		0,63	2,35	2,35	2,35	2,35	2,35	2,35	2,35	2,35
		0,75	2,50	2,50	2,50	2,50	2,50	2,50	2,50	2,50
		0,88	2,50	2,50	2,50	2,50	2,50	2,50	2,50	2,50
		1,00	2,50	2,50	2,50	2,50	2,50	2,50	2,50	2,50
	$N_{R,k}$ in [kN]	0,50	3,65	3,65	3,65	3,65	3,65	3,65	3,65	3,65
		0,55	3,65	3,65	3,65	3,65	3,65	3,65	3,65	3,65
		0,63	4,60	4,60	4,60	4,60	4,60	4,60	4,60	4,60
		0,75	5,45	5,45	5,45	5,45	5,45	5,45	5,45	5,45
		0,88	5,45	5,45	5,45	5,45	5,45	5,45	5,45	5,45
		1,00	5,45	5,45	5,45	5,45	5,45	5,45	5,45	5,45
max. head displacement u depending on the sandwich panel thickness in [mm]	30	1	1	1	1	1	1	1	1	
	40	1	1	1	1	1	1	1	1	
	50	1	1	1	1	1	1	1	1	
	60	2,5	2,5	2,5	2,5	2,5	2,5	2,5	2,5	
	70	2,5	2,5	2,5	2,5	2,5	2,5	2,5	2,5	
	80	2,5	2,5	2,5	2,5	2,5	2,5	2,5	2,5	
	90	4	4	4	4	4	4	4	4	
	100	4	4	4	4	4	4	4	4	
	120	4	4	4	4	4	4	4	4	
	≥ 140	4	4	4	4	4	4	4	4	

Component I: S280GD, S320GD or S350GD – EN 10346

Component II: S235 – EN 10025-1 S280GD, S320GD or S350GD – EN 10346

Table 43.

Self-drilling screw GTR25SP S19 6,3/7,0 x L with hexagon head and stainless steel sealing washer $\varnothing 19$ mm									
Component II: t_{II} in [mm]		4,00	5,00	6,00	8,00	10,00	12,00	14,00	$\geq 15,00$
Component I: $t_{N,1}$ or $t_{N,2}$ in [mm]	$V_{R,k}$ in [kN]	0,50	1,29	1,29	1,29	1,29	1,29	1,29	1,29
		0,55	1,29	1,29	1,29	1,29	1,29	1,29	1,29
		0,63	2,35	2,35	2,35	2,35	2,35	2,35	2,35
		0,75	2,50	2,50	2,50	2,50	2,50	2,50	2,50
		0,88	2,50	2,50	2,50	2,50	2,50	2,50	2,50
		1,00	2,50	2,50	2,50	2,50	2,50	2,50	2,50
	$N_{R,k}$ in [kN]	0,50	3,65	3,65	3,65	3,65	3,65	3,65	3,65
		0,55	3,65	3,65	3,65	3,65	3,65	3,65	3,65
		0,63	4,60	4,60	4,60	4,60	4,60	4,60	4,60
		0,75	5,45	5,45	5,45	5,45	5,45	5,45	5,45
		0,88	5,45	5,45	5,45	5,45	5,45	5,45	5,45
		1,00	5,45	5,45	5,45	5,45	5,45	5,45	5,45
max. head displacement u depending on the sandwich panel thickness in [mm]	30	1	1	1	1	1	1	1	
	40	1	1	1	1	1	1	1	
	50	1	1	1	1	1	1	1	
	60	2,5	2,5	2,5	2,5	2,5	2,5	2,5	
	70	2,5	2,5	2,5	2,5	2,5	2,5	2,5	
	80	2,5	2,5	2,5	2,5	2,5	2,5	2,5	
	90	4	4	4	4	4	4	4	
	100	4	4	4	4	4	4	4	
	120	4	4	4	4	4	4	4	
	≥ 140	4	4	4	4	4	4	4	

Component I: S280GD, S320GD or S350GD – EN 10346

Component II: S235 – EN 10025-1 S280GD, S320GD or S350GD – EN 10346

Table 44.

Self-drilling screw GTR25SP S22 6,3/7,0 x L with hexagon head and stainless steel sealing washer $\varnothing 22$ mm									
Component II: t_{II} in [mm]		4,00	5,00	6,00	8,00	10,00	12,00	14,00	$\geq 15,00$
Component I: $t_{N,1}$ or $t_{N,2}$ in [mm]	$V_{R,k}$ in [kN]	0,50	1,29	1,29	1,29	1,29	1,29	1,29	1,29
		0,55	1,29	1,29	1,29	1,29	1,29	1,29	1,29
		0,63	2,35	2,35	2,35	2,35	2,35	2,35	2,35
		0,75	2,50	2,50	2,50	2,50	2,50	2,50	2,50
		0,88	2,50	2,50	2,50	2,50	2,50	2,50	2,50
		1,00	2,50	2,50	2,50	2,50	2,50	2,50	2,50
	$N_{R,k}$ in [kN]	0,50	3,65	3,65	3,65	3,65	3,65	3,65	3,65
		0,55	3,65	3,65	3,65	3,65	3,65	3,65	3,65
		0,63	4,60	4,60	4,60	4,60	4,60	4,60	4,60
		0,75	5,45	5,45	5,45	5,45	5,45	5,45	5,45
		0,88	5,45	5,45	5,45	5,45	5,45	5,45	5,45
		1,00	5,45	5,45	5,45	5,45	5,45	5,45	5,45
max. head displacement u depending on the sandwich panel thickness in [mm]	30	1	1	1	1	1	1	1	
	40	1	1	1	1	1	1	1	
	50	1	1	1	1	1	1	1	
	60	2,5	2,5	2,5	2,5	2,5	2,5	2,5	
	70	2,5	2,5	2,5	2,5	2,5	2,5	2,5	
	80	2,5	2,5	2,5	2,5	2,5	2,5	2,5	
	90	4	4	4	4	4	4	4	
	100	4	4	4	4	4	4	4	
	120	4	4	4	4	4	4	4	
	≥ 140	4	4	4	4	4	4	4	

Component I: S280GD, S320GD or S350GD – EN 10346

Component II: S235 – EN 10025-1 S280GD, S320GD or S350GD – EN 10346

Table 45.

Self-drilling screw GTR25SP S29 6,3/7,0 x L with hexagon head and stainless steel sealing washer $\varnothing 29$ mm										
Component II: t_{II} in [mm]		4,00	5,00	6,00	8,00	10,00	12,00	14,00	$\geq 15,00$	
Component I: $t_{N,1}$ or $t_{N,2}$ in [mm]	$V_{R,k}$ in [kN]	0,50	1,29	1,29	1,29	1,29	1,29	1,29	1,29	1,29
		0,55	1,29	1,29	1,29	1,29	1,29	1,29	1,29	1,29
		0,63	2,35	2,35	2,35	2,35	2,35	2,35	2,35	2,35
		0,75	2,50	2,50	2,50	2,50	2,50	2,50	2,50	2,50
		0,88	2,50	2,50	2,50	2,50	2,50	2,50	2,50	2,50
		1,00	2,50	2,50	2,50	2,50	2,50	2,50	2,50	2,50
	$N_{R,k}$ in [kN]	0,50	3,65	3,65	3,65	3,65	3,65	3,65	3,65	3,65
		0,55	3,65	3,65	3,65	3,65	3,65	3,65	3,65	3,65
		0,63	4,60	4,60	4,60	4,60	4,60	4,60	4,60	4,60
		0,75	5,45	5,45	5,45	5,45	5,45	5,45	5,45	5,45
		0,88	5,45	5,45	5,45	5,45	5,45	5,45	5,45	5,45
		1,00	5,45	5,45	5,45	5,45	5,45	5,45	5,45	5,45
max. head displacement u depending on the sandwich panel thickness in [mm]	30	1	1	1	1	1	1	1	1	
	40	1	1	1	1	1	1	1	1	
	50	1	1	1	1	1	1	1	1	
	60	2,5	2,5	2,5	2,5	2,5	2,5	2,5	2,5	
	70	2,5	2,5	2,5	2,5	2,5	2,5	2,5	2,5	
	80	2,5	2,5	2,5	2,5	2,5	2,5	2,5	2,5	
	90	4	4	4	4	4	4	4	4	
	100	4	4	4	4	4	4	4	4	
	120	4	4	4	4	4	4	4	4	
	≥ 140	4	4	4	4	4	4	4	4	

Component I: S280GD, S320GD or S350GD – EN 10346

Component II: S235 – EN 10025-1 S280GD, S320GD or S350GD – EN 10346

Table 46.

Self-tapping screw GTRWSP A19 6,4/7,0 x L with hexagon head and aluminum sealing washer Ø19 mm				
Component II: wood class ≥ C24		Effective length l_{ef} [mm]		
		≥ 30	≥ 40	
V _{6,k} [kN] dia t _{6,2} [mm]	0,50	1,74	1,74	Failure of component I
	0,55	1,74	1,74	
	0,63	2,34	2,34	
	0,75	2,45	2,45	
	0,88	2,45	2,45	
	1,00	2,45	2,45	
N _{6,k} [kN] dia t _{6,1} [mm]	0,50	2,45	3,65	Failure of component I
	0,55	2,45	3,65	
	0,63	2,45	4,15	
	0,75	2,45	4,15	
	0,88	2,45	4,15	
	1,00	2,45	4,15	
max. head displacement "u" depending on sandwich panel thickness [mm]	30	1,0	1,0	
	40	1,0	1,0	
	50	1,0	1,0	
	60	1,5	1,5	
	70	1,5	1,5	
	80	1,5	1,5	
	90	2,0	2,0	
	100	2,0	2,0	
	120	2,0	2,0	
	≥ 140	2,0	2,0	

Component I: S280GD, S320GD or S350GD – EN 10346

Component II: structural timber – EN 14081

Table 47.

Self-tapping screw GTRWSP A22 6,4/7,0 x L with hexagon head and aluminum sealing washer $\varnothing 22$ mm				
Component II: wood class \geq C24		Effective length l_{ef} [mm]		
		≥ 30	≥ 40	
V _{6,k} [kN] dla t _{N,2} [mm]	0,50	1,74	1,74	Failure of component I
	0,55	1,74	1,74	
	0,63	2,34	2,34	
	0,75	2,45	2,45	
	0,88	2,45	2,45	
	1,00	2,45	2,45	
N _{R,k} [kN] dla t _{N,1} [mm]	0,50	2,45	3,65	Failure of component I
	0,55	2,45	3,65	
	0,63	2,45	4,15	
	0,75	2,45	4,15	
	0,88	2,45	4,15	
	1,00	2,45	4,15	
max. head displacement "u" depending on sandwich panel thickness [mm]	30	1,0	1,0	
	40	1,0	1,0	
	50	1,0	1,0	
	60	1,5	1,5	
	70	1,5	1,5	
	80	1,5	1,5	
	90	2,0	2,0	
	100	2,0	2,0	
	≥ 140	2,0	2,0	

Component I: S280GD, S320GD or S350GD – EN 10346

Component II: structural timber – EN 14081

Table 48.

Self-tapping screw GTRWSP A29 6,4/7,0 x L with hexagon head and aluminum sealing washer Ø29 mm				
Component II: wood class ≥ C24		Effective length l_{ef} [mm]		
		≥ 30	≥ 40	
V _{R,k} [kN] dia t _{N,2} [mm]	0,50	1,74	1,74	Failure of component I
	0,55	1,74	1,74	
	0,63	2,34	2,34	
	0,75	2,45	2,45	
	0,88	2,45	2,45	
	1,00	2,45	2,45	
N _{R,k} [kN] dia t _{N,1} [mm]	0,50	2,45	3,65	Failure of component I
	0,55	2,45	3,65	
	0,63	2,45	4,15	
	0,75	2,45	4,15	
	0,88	2,45	4,15	
	1,00	2,45	4,15	
max. head displacement "u" depending on sandwich panel thickness [mm]	30	1,0	1,0	
	40	1,0	1,0	
	50	1,0	1,0	
	60	1,5	1,5	
	70	1,5	1,5	
	80	1,5	1,5	
	90	2,0	2,0	
	100	2,0	2,0	
	120	2,0	2,0	
≥ 140	2,0	2,0		

Component I: S280GD, S320GD or S350GD – EN 10346

Component II: structural timber – EN 14081

Table 49.

Self-tapping screw GTRWSP S19 6,4/7,0 x L with hexagon head and stainless steel sealing washer $\varnothing 19$ mm				
Component II: wood class \geq C24		Effective length l_{ef} [mm]		
		≥ 30	≥ 40	
V _{R,k} [kN] dla t _{N,2} [mm]	0,50	1,23	1,23	Failure of component I
	0,55	1,23	1,23	
	0,63	1,63	1,63	
	0,75	1,87	1,87	
	0,88	1,87	1,87	
	1,00	1,87	1,87	
N _{R,k} [kN] dla t _{N,1} [mm]	0,50	3,43	3,43	* Failure of component I ** Failure of Component II
	0,55	3,43	3,43	
	0,63	4,32	4,32	
	0,75	4,16	4,37	
	0,88	4,16	4,37	
	1,00	4,16	4,37	
max. head displacement "u" depending on sandwich panel thickness [mm]	30	1,0	1,0	
	40	1,0	1,0	
	50	1,0	1,0	
	60	1,5	1,5	
	70	1,5	1,5	
	80	1,5	1,5	
	90	2,0	2,0	
	100	2,0	2,0	
	120	2,0	2,0	
	≥ 140	2,0	2,0	

Component I: S280GD, S320GD or S350GD – EN 10346

Component II: structural timber – EN 14081

Table 50.

Self-tapping screw GTRWSP S22 6,4/7,0 x L with hexagon head and stainless steel sealing washer $\varnothing 22$ mm				
Component II: wood class \geq C24		Effective length l_{ef} [mm]		
		≥ 30	≥ 40	
V _{R,k} [kN] dla t _{R,2} [mm]	0,50	1,23	1,23	Failure of component I
	0,55	1,23	1,23	
	0,63	1,63	1,63	
	0,75	1,87	1,87	
	0,88	1,87	1,87	
	1,00	1,87	1,87	
N _{R,k} [kN] dla t _{R,1} [mm]	0,50	3,43*	3,43*	* Failure of component I ** Failure of Component II
	0,55	3,43*	3,43*	
	0,63	4,16**	4,32*	
	0,75	4,16**	4,37**	
	0,88	4,16**	4,37**	
	1,00	4,16**	4,37**	
max. head displacement "u" depending on sandwich panel thickness [mm]	30	1,0	1,0	
	40	1,0	1,0	
	50	1,0	1,0	
	60	1,5	1,5	
	70	1,5	1,5	
	80	1,5	1,5	
	90	2,0	2,0	
	100	2,0	2,0	
	120	2,0	2,0	
	≥ 140	2,0	2,0	

Component I: S280GD, S320GD or S350GD – EN 10346

Component II: structural timber – EN 14081

Table 51.

Self-tapping screw GTRWSP S29 6,4/7,0 x L with hexagon head and stainless steel sealing washer Ø29 mm				
Component II: wood class ≥ C24		Effective length l_{ef} [mm]		
		≥ 30	≥ 40	
V _{R,k} [kN] dia t _{N,2} [mm]	0,50	1,23	1,23	Failure of component I
	0,55	1,23	1,23	
	0,63	1,63	1,63	
	0,75	1,87	1,87	
	0,88	1,87	1,87	
	1,00	1,87	1,87	
N _{R,k} [kN] dia t _{N,1} [mm]	0,50	3,43*	3,43*	* Failure of component I ** Failure of Component II
	0,55	3,43*	3,43*	
	0,63	4,16**	4,32*	
	0,75	4,16**	4,37**	
	0,88	4,16**	4,37**	
	1,00	4,16**	4,37**	
max. head displacement "u" depending on sandwich panel thickness [mm]	30	1,0	1,0	
	40	1,0	1,0	
	50	1,0	1,0	
	60	1,5	1,5	
	70	1,5	1,5	
	80	1,5	1,5	
	90	2,0	2,0	
	100	2,0	2,0	
	120	2,0	2,0	
	≥ 140	2,0	2,0	

Component I: S280GD, S320GD or S350GD – EN 10346

Component II: structural timber – EN 14081

Table 52.

Self-drilling screw GTX6SP S19 5,5/6,3 x L with hexagon head and stainless steel sealing washer $\varnothing 19$ mm									
Component II: t_{II} in [mm]		1,00	1,50	2,00	2,50	3,00	4,00	$\geq 5,00$	
Component I: $t_{N,1}$ or $t_{N,2}$ in [mm]	$V_{R,k}$ in [kN]	0,50	1,40	1,40	1,40	1,40	1,40	1,40	
		0,55	1,40	1,40	1,40	1,40	1,40	1,40	
		0,63	1,60	1,60	1,60	1,60	1,60	1,60	
		0,75	2,10	2,10	2,10	2,10	2,10	2,10	
		0,88	2,10	2,10	2,10	2,10	2,10	2,10	
		1,00	2,10	2,10	2,10	2,10	2,10	2,10	
	$N_{R,k}$ in [kN]	0,50	1,04	1,92	2,56	2,56	2,56	3,06	3,06
		0,55	1,04	1,92	2,56	2,56	2,56	3,06	3,06
		0,63	1,04	1,92	2,56	2,56	2,56	3,86	3,86
		0,75	1,04	1,92	2,56	2,56	2,56	5,39	5,39
		0,88	1,04	1,92	2,56	2,56	2,56	5,39	5,39
		1,00	1,04	1,92	2,56	2,56	2,56	5,39	5,39
max. head displacement u depending on the sandwich panel thickness in [mm]	30	12	12	12	12	1,5	1,5	1,5	
	40	12	12	12	12	1,5	1,5	1,5	
	50	12	12	12	12	1,5	1,5	1,5	
	60	18	18	18	18	4	4	4	
	70	18	18	18	18	4	4	4	
	80	18	18	18	18	4	4	4	
	90	23	23	23	23	10	10	10	
	100	23	23	23	23	10	10	10	
	120	23	23	23	23	10	10	10	
	≥ 140	23	23	23	23	10	10	10	

Component I: S280GD, S320GD or S350GD – EN 10346

Component II: S235 – EN 10025-1 S280GD, S320GD or S350GD – EN 10346

Table 53.

Self-drilling screw GTX6SP S22 5,5/6,3 x L with hexagon head and stainless steel sealing washer $\varnothing 22$ mm									
Component II: t_{II} in [mm]		1,00	1,50	2,00	2,50	3,00	4,00	$\geq 5,00$	
Component I: $t_{N,1}$ or $t_{N,2}$ in [mm]	$V_{R,k}$ in [kN]	0,50	1,40	1,40	1,40	1,40	1,40	1,40	
		0,55	1,40	1,40	1,40	1,40	1,40	1,40	
		0,63	1,60	1,60	1,60	1,60	1,60	1,60	
		0,75	2,10	2,10	2,10	2,10	2,10	2,10	
		0,88	2,10	2,10	2,10	2,10	2,10	2,10	
		1,00	2,10	2,10	2,10	2,10	2,10	2,10	
	$N_{R,k}$ in [kN]	0,50	1,04	1,92	2,56	2,56	2,56	3,43	3,43
		0,55	1,04	1,92	2,56	2,56	2,56	3,43	3,43
		0,63	1,04	1,92	2,56	2,56	2,56	4,32	4,32
		0,75	1,04	1,92	2,56	2,56	2,56	6,10	6,10
		0,88	1,04	1,92	2,56	2,56	2,56	6,10	6,10
		1,00	1,04	1,92	2,56	2,56	2,56	6,10	6,10
max. head displacement u depending on the sandwich panel thickness in [mm]	30	12	12	12	12	1,5	1,5	1,5	
	40	12	12	12	12	1,5	1,5	1,5	
	50	12	12	12	12	1,5	1,5	1,5	
	60	18	18	18	18	4	4	4	
	70	18	18	18	18	4	4	4	
	80	18	18	18	18	4	4	4	
	90	23	23	23	23	10	10	10	
	100	23	23	23	23	10	10	10	
	120	23	23	23	23	10	10	10	
	≥ 140	23	23	23	23	10	10	10	

Component I: S280GD, S320GD or S350GD – EN 10346

Component II: S235 – EN 10025-1 S280GD, S320GD or S350GD – EN 10346

Table 54.

Self-drilling screw GTX6SP S29 5,5/6,3 x L with hexagon head and stainless steel sealing washer $\varnothing 29$ mm									
Component II: t_{II} in [mm]		1,00	1,50	2,00	2,50	3,00	4,00	$\geq 5,00$	
Component I: $t_{N,1}$ or $t_{N,2}$ in [mm]	$V_{R,k}$ in [kN]	0,50	1,40	1,40	1,40	1,40	1,40	1,40	1,40
		0,55	1,40	1,40	1,40	1,40	1,40	1,40	1,40
		0,63	1,60	1,60	1,60	1,60	1,60	1,60	1,60
		0,75	2,10	2,10	2,10	2,10	2,10	2,10	2,10
		0,88	2,10	2,10	2,10	2,10	2,10	2,10	2,10
		1,00	2,10	2,10	2,10	2,10	2,10	2,10	2,10
	$N_{R,k}$ in [kN]	0,50	1,04	1,92	2,56	2,56	2,56	4,23	4,23
		0,55	1,04	1,92	2,56	2,56	2,56	4,23	4,23
		0,63	1,04	1,92	2,56	2,56	2,56	5,82	5,82
		0,75	1,04	1,92	2,56	2,56	2,56	6,35	6,35
		0,88	1,04	1,92	2,56	2,56	2,56	6,35	6,35
		1,00	1,04	1,92	2,56	2,56	2,56	6,35	6,35
max. head displacement u depending on the sandwich panel thickness in [mm]	30	12	12	12	12	1,5	1,5	1,5	
	40	12	12	12	12	1,5	1,5	1,5	
	50	12	12	12	12	1,5	1,5	1,5	
	60	18	18	18	18	4	4	4	
	70	18	18	18	18	4	4	4	
	80	18	18	18	18	4	4	4	
	90	23	23	23	23	10	10	10	
	100	23	23	23	23	10	10	10	
	120	23	23	23	23	10	10	10	
	≥ 140	23	23	23	23	10	10	10	

Component I: S280GD, S320GD or S350GD – EN 10346

Component II: S235 – EN 10025-1 S280GD, S320GD or S350GD – EN 10346

Table 55.

Self-drilling screw GTX12SP S19 5,5/6,3 x L with hexagon head and stainless steel sealing washer $\varnothing 19$ mm									
Component II: t_{II} in [mm]		3,00	4,00	5,00	6,00	8,00	10,00	$\geq 11,00$	
Component I: $t_{N,1}$ or $t_{N,2}$ in [mm]	$V_{R,k}$ in [kN]	0,50	1,40	1,40	1,40	1,40	1,40	1,40	1,40
		0,55	1,40	1,40	1,40	1,40	1,40	1,40	1,40
		0,63	1,60	1,60	1,60	1,60	1,60	1,60	1,60
		0,75	2,10	2,10	2,10	2,10	2,10	2,10	2,10
		0,88	2,10	2,10	2,10	2,10	2,10	2,10	2,10
		1,00	2,10	2,10	2,10	2,10	2,10	2,10	2,10
	$N_{R,k}$ in [kN]	0,50	3,06	3,06	3,06	3,06	3,06	3,06	3,06
		0,55	3,06	3,06	3,06	3,06	3,06	3,06	3,06
		0,63	3,86	3,86	3,86	3,86	3,86	3,86	3,86
		0,75	5,39	5,39	5,39	5,39	5,39	5,39	5,39
		0,88	5,39	5,39	5,39	5,39	5,39	5,39	5,39
		1,00	5,39	5,39	5,39	5,39	5,39	5,39	5,39
max. head displacement u depending on the sandwich panel thickness in [mm]	30	1,5	1,5	1,5	1,5	1,5	1,5	1,5	
	40	1,5	1,5	1,5	1,5	1,5	1,5	1,5	
	50	1,5	1,5	1,5	1,5	1,5	1,5	1,5	
	60	4	4	4	4	4	4	4	
	70	4	4	4	4	4	4	4	
	80	4	4	4	4	4	4	4	
	90	6	6	6	6	6	6	6	
	100	6	6	6	6	6	6	6	
	120	6	6	6	6	6	6	6	
	≥ 140	6	6	6	6	6	6	6	

Component I: S280GD, S320GD or S350GD – EN 10346

Component II: S235 – EN 10025-1 S280GD, S320GD or S350GD – EN 10346

Table 56.

Self-drilling screw GTX12SP S22 5,5/6,3 x L with hexagon head and stainless steel sealing washer $\varnothing 22$ mm									
Component II: t_{II} in [mm]		3,00	4,00	5,00	6,00	8,00	10,00	$\geq 11,00$	
Component I: $t_{N,1}$ or $t_{N,2}$ in [mm]	$V_{R,k}$ in [kN]	0,50	1,40	1,40	1,40	1,40	1,40	1,40	1,40
		0,55	1,40	1,40	1,40	1,40	1,40	1,40	1,40
		0,63	1,60	1,60	1,60	1,60	1,60	1,60	1,60
		0,75	2,10	2,10	2,10	2,10	2,10	2,10	2,10
		0,88	2,10	2,10	2,10	2,10	2,10	2,10	2,10
		1,00	2,10	2,10	2,10	2,10	2,10	2,10	2,10
	$N_{R,k}$ in [kN]	0,50	3,43	3,43	3,43	3,43	3,43	3,43	3,43
		0,55	3,43	3,43	3,43	3,43	3,43	3,43	3,43
		0,63	4,32	4,32	4,32	4,32	4,32	4,32	4,32
		0,75	6,10	6,10	6,10	6,10	6,10	6,10	6,10
		0,88	6,10	6,10	6,10	6,10	6,10	6,10	6,10
		1,00	6,10	6,10	6,10	6,10	6,10	6,10	6,10
max. head displacement u depending on the sandwich panel thickness in [mm]	30	1,5	1,5	1,5	1,5	1,5	1,5	1,5	
	40	1,5	1,5	1,5	1,5	1,5	1,5	1,5	
	50	1,5	1,5	1,5	1,5	1,5	1,5	1,5	
	60	4	4	4	4	4	4	4	
	70	4	4	4	4	4	4	4	
	80	4	4	4	4	4	4	4	
	90	6	6	6	6	6	6	6	
	100	6	6	6	6	6	6	6	
	120	6	6	6	6	6	6	6	
	≥ 140	6	6	6	6	6	6	6	

Component I: S280GD, S320GD or S350GD – EN 10346

Component II: S235 – EN 10025-1 S280GD, S320GD or S350GD – EN 10346

Table 57.

Self-drilling screw GTX12SP S29 5,5/6,3 x L with hexagon head and stainless steel sealing washer $\varnothing 29$ mm									
Component II: t_{II} in [mm]		3,00	4,00	5,00	6,00	8,00	10,00	$\geq 11,00$	
Component I: $t_{N,1}$ or $t_{N,2}$ in [mm]	$V_{R,k}$ in [kN]	0,50	1,40	1,40	1,40	1,40	1,40	1,40	1,40
		0,55	1,40	1,40	1,40	1,40	1,40	1,40	1,40
		0,63	1,60	1,60	1,60	1,60	1,60	1,60	1,60
		0,75	2,10	2,10	2,10	2,10	2,10	2,10	2,10
		0,88	2,10	2,10	2,10	2,10	2,10	2,10	2,10
		1,00	2,10	2,10	2,10	2,10	2,10	2,10	2,10
	$N_{R,k}$ in [kN]	0,50	4,23	4,23	4,23	4,23	4,23	4,23	4,23
		0,55	4,23	4,23	4,23	4,23	4,23	4,23	4,23
		0,63	5,82	5,82	5,82	5,82	5,82	5,82	5,82
		0,75	6,35	6,35	6,35	6,35	6,35	6,35	6,35
		0,88	6,35	6,35	6,35	6,35	6,35	6,35	6,35
		1,00	6,35	6,35	6,35	6,35	6,35	6,35	6,35
max. head displacement u depending on the sandwich panel thickness in [mm]	30	1,5	1,5	1,5	1,5	1,5	1,5	1,5	
	40	1,5	1,5	1,5	1,5	1,5	1,5	1,5	
	50	1,5	1,5	1,5	1,5	1,5	1,5	1,5	
	60	4	4	4	4	4	4	4	
	70	4	4	4	4	4	4	4	
	80	4	4	4	4	4	4	4	
	90	6	6	6	6	6	6	6	
	100	6	6	6	6	6	6	6	
	120	6	6	6	6	6	6	6	
	≥ 140	6	6	6	6	6	6	6	

Component I: S280GD, S320GD or S350GD – EN 10346

Component II: S235 – EN 10025-1 S280GD, S320GD or S350GD – EN 10346

Table 58.

Self-drilling screws GT6SP Z19 5,5/6,3 x L, GT6SP Z22 5,5/6,3 x L, GT6SP Z29 5,5/6,3 x L, GT6SP A19 5,5/6,3 x L, GT6SP A22 5,5/6,3 x L, GT6SP A29 5,5/6,3 x L, GT6SP S19 5,5/6,3 x L, GT6SP S22 5,5/6,3 x L and GT6SP S29 5,5/6,3 x L, with hexagon head and carbon steel, aluminum or stainless steel sealing washer $\varnothing 19, 22$ or 29 mm and with GSPW washer									
Component II: t_{II} in [mm]		1,00	1,50	2,00	2,50	3,00	4,00	$\geq 5,00$	
Component I: $t_{N,1}$ or $t_{N,2}$ in [mm]	$V_{R,x}$ in [kN]	0,50	1,40	1,40	1,40	1,40	1,40	1,40	
		0,55	1,40	1,40	1,40	1,40	1,40	1,40	
		0,63	1,60	1,60	1,60	1,60	1,60	1,60	
		0,75	2,10	2,10	2,10	2,10	2,10	2,10	
		0,88	2,10	2,10	2,10	2,10	2,10	2,10	
		1,00	2,10	2,10	2,10	2,10	2,10	2,10	
	$N_{R,x}$ in [kN]	0,50	1,10	1,93	2,56	2,56	2,56	4,45	4,45
		0,55	1,10	1,93	2,56	2,56	2,56	4,45	4,45
		0,63	1,10	1,93	2,56	2,56	2,56	4,45	4,45
		0,75	1,10	1,93	2,56	2,56	2,56	4,45	4,45
		0,88	1,10	1,93	2,56	2,56	2,56	4,45	4,45
		1,00	1,10	1,93	2,56	2,56	2,56	4,45	4,45
max. head displacement u depending on the sandwich panel thickness in [mm]	30	12	12	12	12	1,5	1,5	1,5	
	40	12	12	12	12	1,5	1,5	1,5	
	50	12	12	12	12	1,5	1,5	1,5	
	60	18	18	18	18	4	4	4	
	70	18	18	18	18	4	4	4	
	80	18	18	18	18	4	4	4	
	90	23	23	23	23	10	10	10	
	100	23	23	23	23	10	10	10	
	120	23	23	23	23	10	10	10	
	≥ 140	23	23	23	23	10	10	10	

Component I: S280GD, S320GD or S350GD – EN 10346

Component II: S235 – EN 10025-1 S280GD, S320GD or S350GD – EN 10346

Table 59.

Self-drilling screws GT12SP Z19 5,5/6,3 x L, GT12SP Z22 5,5/6,3 x L, GT12SP Z29 5,5/6,3 x L, GT12SP A19 5,5/6,3 x L, GT12SP A22 5,5/6,3 x L, GT12SP A29 5,5/6,3 x L, GT12SP S19 5,5/6,3 x L, GT12SP S22 5,5/6,3 x L and GT12SP S29 5,5/6,3 x L, with hexagon head and carbon steel, aluminum or stainless steel sealing washer $\varnothing 19, 22$ or 29 mm and with GSPW washer									
Component II: t_{II} in [mm]		3,00	4,00	5,00	6,00	8,00	10,00	$\geq 11,00$	
Component I: $t_{N,1}$ or $t_{N,2}$ in [mm]	$V_{R,k}$ in [kN]	0,50	1,40	1,40	1,40	1,40	1,40	1,40	1,40
		0,55	1,40	1,40	1,40	1,40	1,40	1,40	1,40
		0,63	1,60	1,60	1,60	1,60	1,60	1,60	1,60
		0,75	2,10	2,10	2,10	2,10	2,10	2,10	2,10
		0,88	2,10	2,10	2,10	2,10	2,10	2,10	2,10
		1,00	2,10	2,10	2,10	2,10	2,10	2,10	2,10
	$N_{R,k}$ in [kN]	0,50	4,45	4,45	4,45	4,45	4,45	4,45	4,45
		0,55	4,45	4,45	4,45	4,45	4,45	4,45	4,45
		0,63	4,45	4,45	4,45	4,45	4,45	4,45	4,45
		0,75	4,45	4,45	4,45	4,45	4,45	4,45	4,45
		0,88	4,45	4,45	4,45	4,45	4,45	4,45	4,45
		1,00	4,45	4,45	4,45	4,45	4,45	4,45	4,45
max. head displacement u depending on the sandwich panel thickness in [mm]	30	1,5	1,5	1,5	1,5	1,5	1,5	1,5	
	40	1,5	1,5	1,5	1,5	1,5	1,5	1,5	
	50	1,5	1,5	1,5	1,5	1,5	1,5	1,5	
	60	4	4	4	4	4	4	4	
	70	4	4	4	4	4	4	4	
	80	4	4	4	4	4	4	4	
	90	6	6	6	6	6	6	6	
	100	6	6	6	6	6	6	6	
	120	6	6	6	6	6	6	6	
≥ 140	6	6	6	6	6	6	6		

Component I: S280GD, S320GD or S350GD – EN 10346

Component II: S235 – EN 10025-1 S280GD, S320GD or S350GD – EN 10346

Table 60.

Self-drilling screws GT16SP Z19 5,5/6,3 x L, GT16SP Z22 5,5/6,3 x L, GT16SP Z29 5,5/6,3 x L, GT16SP A19 5,5/6,3 x L, GT16SP A22 5,5/6,3 x L, GT16SP A29 5,5/6,3 x L, GT16SP S19 5,5/6,3 x L, GT16SP S22 5,5/6,3 x L and GT16SP S29 5,5/6,3 x L, with hexagon head and carbon steel, aluminum or stainless steel sealing washer $\varnothing 19, 22$ or 29 mm and with GSPW washer										
Component II: t_{II} in [mm]		4,00	5,00	6,00	8,00	10,00	12,00	14,00	$\geq 15,00$	
Component I: $t_{N,1}$ or $t_{N,2}$ in [mm]	$V_{R,k}$ in [kN]	0,50	1,29	1,29	1,29	1,29	1,29	1,29	1,29	1,29
		0,55	1,29	1,29	1,29	1,29	1,29	1,29	1,29	1,29
		0,63	2,35	2,35	2,35	2,35	2,35	2,35	2,35	2,35
		0,75	2,50	2,50	2,50	2,50	2,50	2,50	2,50	2,50
		0,88	2,50	2,50	2,50	2,50	2,50	2,50	2,50	2,50
		1,00	2,50	2,50	2,50	2,50	2,50	2,50	2,50	2,50
	$N_{R,k}$ in [kN]	0,50	4,45	4,45	4,45	4,45	4,45	4,45	4,45	4,45
		0,55	4,45	4,45	4,45	4,45	4,45	4,45	4,45	4,45
		0,63	4,45	4,45	4,45	4,45	4,45	4,45	4,45	4,45
		0,75	4,45	4,45	4,45	4,45	4,45	4,45	4,45	4,45
		0,88	4,45	4,45	4,45	4,45	4,45	4,45	4,45	4,45
		1,00	4,45	4,45	4,45	4,45	4,45	4,45	4,45	4,45
max. head displacement u depending on the sandwich panel thickness in [mm]	30	1	1	1	1	1	1	1	1	
	40	1	1	1	1	1	1	1	1	
	50	1	1	1	1	1	1	1	1	
	60	2,5	2,5	2,5	2,5	2,5	2,5	2,5	2,5	
	70	2,5	2,5	2,5	2,5	2,5	2,5	2,5	2,5	
	80	2,5	2,5	2,5	2,5	2,5	2,5	2,5	2,5	
	90	4	4	4	4	4	4	4	4	
	100	4	4	4	4	4	4	4	4	
	120	4	4	4	4	4	4	4	4	
	≥ 140	4	4	4	4	4	4	4	4	

Component I: S280GD, S320GD or S350GD – EN 10346

Component II: S235 – EN 10025-1 S280GD, S320GD or S350GD – EN 10346

Table 61.

Self-drilling screws GT20SP Z19 5,5/6,3 x L, GT20SP Z22 5,5/6,3 x L, GT20SP Z29 5,5/6,3 x L, GT20SP A19 5,5/6,3 x L, GT20SP A22 5,5/6,3 x L, GT20SP A29 5,5/6,3 x L, GT20SP S19 5,5/6,3 x L, GT20SP S22 5,5/6,3 x L and GT20SP S29 5,5/6,3 x L, with hexagon head and carbon steel, aluminum or stainless steel sealing washer $\varnothing 19, 22$ or 29 mm and with GSPW washer										
Component II: t_{II} in [mm]		4,00	5,00	6,00	8,00	10,00	12,00	14,00	$\geq 15,00$	
Component I: $t_{N,1}$ or $t_{N,2}$ in [mm]	$V_{R,k}$ in [kN]	0,50	1,29	1,29	1,29	1,29	1,29	1,29	1,29	1,29
		0,55	1,29	1,29	1,29	1,29	1,29	1,29	1,29	1,29
		0,63	2,35	2,35	2,35	2,35	2,35	2,35	2,35	2,35
		0,75	2,50	2,50	2,50	2,50	2,50	2,50	2,50	2,50
		0,88	2,50	2,50	2,50	2,50	2,50	2,50	2,50	2,50
		1,00	2,50	2,50	2,50	2,50	2,50	2,50	2,50	2,50
	$N_{R,k}$ in [kN]	0,50	4,45	4,45	4,45	4,45	4,45	4,45	4,45	4,45
		0,55	4,45	4,45	4,45	4,45	4,45	4,45	4,45	4,45
		0,63	4,45	4,45	4,45	4,45	4,45	4,45	4,45	4,45
		0,75	4,45	4,45	4,45	4,45	4,45	4,45	4,45	4,45
		0,88	4,45	4,45	4,45	4,45	4,45	4,45	4,45	4,45
		1,00	4,45	4,45	4,45	4,45	4,45	4,45	4,45	4,45
max. head displacement u depending on the sandwich panel thickness in [mm]	30	1	1	1	1	1	1	1	1	
	40	1	1	1	1	1	1	1	1	
	50	1	1	1	1	1	1	1	1	
	60	2,5	2,5	2,5	2,5	2,5	2,5	2,5	2,5	
	70	2,5	2,5	2,5	2,5	2,5	2,5	2,5	2,5	
	80	2,5	2,5	2,5	2,5	2,5	2,5	2,5	2,5	
	90	4	4	4	4	4	4	4	4	
	100	4	4	4	4	4	4	4	4	
	120	4	4	4	4	4	4	4	4	
	≥ 140	4	4	4	4	4	4	4	4	

Component I: S280GD, S320GD or S350GD – EN 10346

Component II: S235 – EN 10025-1 S280GD, S320GD or S350GD – EN 10346

Table 62.

Self-drilling screws GT25SP Z19 5,5/6,3 x L, GT25SP Z22 5,5/6,3 x L, GT25SP Z29 5,5/6,3 x L, GT25SP A19 5,5/6,3 x L, GT25SP A22 5,5/6,3 x L, GT25SP A29 5,5/6,3 x L, GT25SP S19 5,5/6,3 x L, GT25SP S22 5,5/6,3 x L and GT25SP S29 5,5/6,3 x L, with hexagon head and carbon steel, aluminum or stainless steel sealing washer Ø19, 22 or 29 mm and with GSPW washer										
Component II: t_{II} in [mm]		4,00	5,00	6,00	8,00	10,00	12,00	14,00	≥ 15,00	
Component I: $t_{N,1}$ or $t_{N,2}$ in [mm]	$V_{R,k}$ in [kN]	0,50	1,29	1,29	1,29	1,29	1,29	1,29	1,29	1,29
		0,55	1,29	1,29	1,29	1,29	1,29	1,29	1,29	1,29
		0,63	2,35	2,35	2,35	2,35	2,35	2,35	2,35	2,35
		0,75	2,50	2,50	2,50	2,50	2,50	2,50	2,50	2,50
		0,88	2,50	2,50	2,50	2,50	2,50	2,50	2,50	2,50
		1,00	2,50	2,50	2,50	2,50	2,50	2,50	2,50	2,50
	$N_{R,k}$ in [kN]	0,50	4,45	4,45	4,45	4,45	4,45	4,45	4,45	4,45
		0,55	4,45	4,45	4,45	4,45	4,45	4,45	4,45	4,45
		0,63	4,45	4,45	4,45	4,45	4,45	4,45	4,45	4,45
		0,75	4,45	4,45	4,45	4,45	4,45	4,45	4,45	4,45
		0,88	4,45	4,45	4,45	4,45	4,45	4,45	4,45	4,45
		1,00	4,45	4,45	4,45	4,45	4,45	4,45	4,45	4,45
max. head displacement u depending on the sandwich panel thickness in [mm]	30	1	1	1	1	1	1	1	1	
	40	1	1	1	1	1	1	1	1	
	50	1	1	1	1	1	1	1	1	
	60	2,5	2,5	2,5	2,5	2,5	2,5	2,5	2,5	
	70	2,5	2,5	2,5	2,5	2,5	2,5	2,5	2,5	
	80	2,5	2,5	2,5	2,5	2,5	2,5	2,5	2,5	
	90	4	4	4	4	4	4	4	4	
	100	4	4	4	4	4	4	4	4	
	120	4	4	4	4	4	4	4	4	
	≥ 140	4	4	4	4	4	4	4	4	

Component I: S280GD, S320GD or S350GD – EN 10346

Component II: S235 – EN 10025-1 S280GD, S320GD or S350GD – EN 10346

Table 63.

Self-drilling screws GTRWSP A19 6,4/7,0 x L, GTRWSP A22 6,4/7,0 x L, GTRWSP A29 6,4/7,0 x L, GTRWSP S19 6,4/7,0 x L, GTRWSP S22 6,4/7,0 x L and GTRWSP S29 6,4/7,0 x L with hexagon head and aluminum or stainless steel sealing washer Ø19, 22 or 29 mm and with GSPW washer				
Component II: wood class ≥ C24		Effective length l_{ef} [mm]		
		≥ 30	≥ 40	
V _{R,k} [kN] dla t _{0,2} [mm]	0,50	1,23	1,23	Failure of component I
	0,55	1,23	1,23	
	0,63	1,63	1,63	
	0,75	1,87	1,87	
	0,88	1,87	1,87	
	1,00	1,87	1,87	
N _{R,k} [kN] dla t _{0,1} [mm]	0,50	4,16	4,37	Failure of component I
	0,55	4,16	4,37	
	0,63	4,16	4,37	
	0,75	4,16	4,37	
	0,88	4,16	4,37	
	1,00	4,16	4,37	
max. head displacement "u" depending on sandwich panel thickness [mm]	30	1,0	1,0	
	40	1,0	1,0	
	50	1,0	1,0	
	60	1,5	1,5	
	70	1,5	1,5	
	80	1,5	1,5	
	90	2,0	2,0	
	100	2,0	2,0	
	120	2,0	2,0	
	≥ 140	2,0	2,0	

Component I: S280GD, S320GD or S350GD – EN 10346

Component II: structural timber – EN 14081

Table 64.

Self-drilling screws GTX6SP S19 5,5/6,3 x L, GTX6SP S22 5,5/6,3 x L and GTX6SP S29 5,5/6,3 x L, with hexagon head and aluminum or stainless steel sealing washer $\varnothing 19, 22$ or 29 mm and with GSPW washer									
Component II: t_{II} in [mm]		1,00	1,50	2,00	2,50	3,00	4,00	$\geq 5,00$	
Component I: $t_{I,1}$ or $t_{I,2}$ in [mm]	$V_{R,k}$ in [kN]	0,50	1,40	1,40	1,40	1,40	1,40	1,40	1,40
		0,55	1,40	1,40	1,40	1,40	1,40	1,40	1,40
		0,63	1,60	1,60	1,60	1,60	1,60	1,60	1,60
		0,75	2,10	2,10	2,10	2,10	2,10	2,10	2,10
		0,88	2,10	2,10	2,10	2,10	2,10	2,10	2,10
		1,00	2,10	2,10	2,10	2,10	2,10	2,10	2,10
	$N_{R,k}$ in [kN]	0,50	1,04	1,92	2,56	2,56	2,56	4,45	4,45
		0,55	1,04	1,92	2,56	2,56	2,56	4,45	4,45
		0,63	1,04	1,92	2,56	2,56	2,56	4,45	4,45
		0,75	1,04	1,92	2,56	2,56	2,56	4,45	4,45
		0,88	1,04	1,92	2,56	2,56	2,56	4,45	4,45
		1,00	1,04	1,92	2,56	2,56	2,56	4,45	4,45
max. head displacement u depending on the sandwich panel thickness in [mm]	30	12	12	12	12	1,5	1,5	1,5	
	40	12	12	12	12	1,5	1,5	1,5	
	50	12	12	12	12	1,5	1,5	1,5	
	60	18	18	18	18	4	4	4	
	70	18	18	18	18	4	4	4	
	80	18	18	18	18	4	4	4	
	90	23	23	23	23	10	10	10	
	100	23	23	23	23	10	10	10	
	120	23	23	23	23	10	10	10	
	≥ 140	23	23	23	23	10	10	10	

Component I: S280GD, S320GD or S350GD – EN 10346

Component II: S235 – EN 10025-1 S280GD, S320GD or S350GD – EN 10346

Table 65.

Self-drilling screws GTX12SP S19 5,5/6,3 x L, GTX12SP S22 5,5/6,3 x L and GTX12SP S29 5,5/6,3 x L, with hexagon head and aluminum or stainless steel sealing washer $\varnothing 19, 22$ or 29 mm and with GSPW washer								
Component II: t_{II} in [mm]		3,00	4,00	5,00	6,00	8,00	10,00	$\geq 11,00$
Component I: $t_{N,1}$ or $t_{N,2}$ in [mm]	$V_{R,k}$ in [kN]	0,50	1,40	1,40	1,40	1,40	1,40	1,40
		0,55	1,40	1,40	1,40	1,40	1,40	1,40
		0,63	1,60	1,60	1,60	1,60	1,60	1,60
		0,75	2,10	2,10	2,10	2,10	2,10	2,10
		0,88	2,10	2,10	2,10	2,10	2,10	2,10
		1,00	2,10	2,10	2,10	2,10	2,10	2,10
	$N_{R,k}$ in [kN]	0,50	4,45	4,45	4,45	4,45	4,45	4,45
		0,55	4,45	4,45	4,45	4,45	4,45	4,45
		0,63	4,45	4,45	4,45	4,45	4,45	4,45
		0,75	4,45	4,45	4,45	4,45	4,45	4,45
		0,88	4,45	4,45	4,45	4,45	4,45	4,45
		1,00	4,45	4,45	4,45	4,45	4,45	4,45
max. head displacement u depending on the sandwich panel thickness in [mm]	30	1,5	1,5	1,5	1,5	1,5	1,5	
	40	1,5	1,5	1,5	1,5	1,5	1,5	
	50	1,5	1,5	1,5	1,5	1,5	1,5	
	60	4	4	4	4	4	4	
	70	4	4	4	4	4	4	
	80	4	4	4	4	4	4	
	90	6	6	6	6	6	6	
	100	6	6	6	6	6	6	
	120	6	6	6	6	6	6	
	≥ 140	6	6	6	6	6	6	

Component I: S280GD, S320GD or S350GD – EN 10346

Component II: S235 – EN 10025-1 S280GD, S320GD or S350GD – EN 10346

Table 66.

Self-drilling screws GT6SP Z19 5,5/6,3 x L, GT6SP Z22 5,5/6,3 x L, GT6SP Z29 5,5/6,3 x L, GT6SP A19 5,5/6,3 x L, GT6SP A22 5,5/6,3 x L, GT6SP A29 5,5/6,3 x L, GT6SP S19 5,5/6,3 x L, GT6SP S22 5,5/6,3 x L and GT6SP S29 5,5/6,3 x L, with hexagon head and carbon steel, aluminum or stainless steel sealing washer Ø19, 22 or 29 mm and with saddle washer									
Component II: t_{II} in [mm]		1,00	1,50	2,00	2,50	3,00	4,00	≥ 5,00	
Component I: $t_{N,1}$ or $t_{N,2}$ in [mm]	$V_{R,k}$ in [kN]	0,50	1,40	1,40	1,40	1,40	1,40	1,40	1,40
		0,55	1,40	1,40	1,40	1,40	1,40	1,40	1,40
		0,63	1,60	1,60	1,60	1,60	1,60	1,60	1,60
		0,75	2,10	2,10	2,10	2,10	2,10	2,10	2,10
		0,88	2,10	2,10	2,10	2,10	2,10	2,10	2,10
		1,00	2,10	2,10	2,10	2,10	2,10	2,10	2,10
	$N_{R,k}$ in [kN]	0,50	1,10	1,93	2,56	2,56	2,56	6,54	6,54
		0,55	1,10	1,93	2,56	2,56	2,56	6,54	6,54
		0,63	1,10	1,93	2,56	2,56	2,56	6,54	6,54
		0,75	1,10	1,93	2,56	2,56	2,56	6,54	6,54
		0,88	1,10	1,93	2,56	2,56	2,56	6,54	6,54
		1,00	1,10	1,93	2,56	2,56	2,56	6,54	6,54
max. head displacement u depending on the sandwich panel thickness in [mm]	30	12	12	12	12	1,5	1,5	1,5	
	40	12	12	12	12	1,5	1,5	1,5	
	50	12	12	12	12	1,5	1,5	1,5	
	60	18	18	18	18	4	4	4	
	70	18	18	18	18	4	4	4	
	80	18	18	18	18	4	4	4	
	90	23	23	23	23	10	10	10	
	100	23	23	23	23	10	10	10	
	120	23	23	23	23	10	10	10	
	≥140	23	23	23	23	10	10	10	

Component I: S280GD, S320GD or S350GD – EN 10346

Component II: S235 – EN 10025-1 S280GD, S320GD or S350GD – EN 10346

Table 67.

Self-drilling screws GT12SP Z19 5,5/6,3 x L, GT12SP Z22 5,5/6,3 x L, GT12SP Z29 5,5/6,3 x L, GT12SP A19 5,5/6,3 x L, GT12SP A22 5,5/6,3 x L, GT12SP A29 5,5/6,3 x L, GT12SP S19 5,5/6,3 x L, GT12SP S22 5,5/6,3 x L and GT12SP S29 5,5/6,3 x L, with hexagon head and carbon steel, aluminum or stainless steel sealing washer $\varnothing 19, 22$ or 29 mm and with saddle washer									
Component II: t_{II} in [mm]		3,00	4,00	5,00	6,00	8,00	10,00	$\geq 11,00$	
Component I: $t_{w,1}$ or $t_{w,2}$ in [mm]	$V_{6,k}$ in [kN]	0,50	1,40	1,40	1,40	1,40	1,40	1,40	1,40
		0,55	1,40	1,40	1,40	1,40	1,40	1,40	1,40
		0,63	1,60	1,60	1,60	1,60	1,60	1,60	1,60
		0,75	2,10	2,10	2,10	2,10	2,10	2,10	2,10
		0,88	2,10	2,10	2,10	2,10	2,10	2,10	2,10
		1,00	2,10	2,10	2,10	2,10	2,10	2,10	2,10
	$N_{6,k}$ in [kN]	0,50	3,65	6,64	6,64	6,64	6,64	6,64	6,64
		0,55	3,65	6,64	6,64	6,64	6,64	6,64	6,64
		0,63	4,60	6,64	6,64	6,64	6,64	6,64	6,64
		0,75	5,45	6,64	6,64	6,64	6,64	6,64	6,64
		0,88	5,45	6,64	6,64	6,64	6,64	6,64	6,64
		1,00	5,45	6,64	6,64	6,64	6,64	6,64	6,64
max. head displacement u depending on the sandwich panel thickness in [mm]	30	1,5	1,5	1,5	1,5	1,5	1,5	1,5	
	40	1,5	1,5	1,5	1,5	1,5	1,5	1,5	
	50	1,5	1,5	1,5	1,5	1,5	1,5	1,5	
	60	4	4	4	4	4	4	4	
	70	4	4	4	4	4	4	4	
	80	4	4	4	4	4	4	4	
	90	6	6	6	6	6	6	6	
	100	6	6	6	6	6	6	6	
	120	6	6	6	6	6	6	6	
	≥ 140	6	6	6	6	6	6	6	

Component I: S280GD, S320GD or S350GD – EN 10346

Component II: S235 – EN 10025-1 S280GD, S320GD or S350GD – EN 10346

Table 68.

Self-drilling screws GT16SP Z19 5,5/6,3 x L, GT16SP Z22 5,5/6,3 x L, GT16SP Z29 5,5/6,3 x L, GT16SP A19 5,5/6,3 x L, GT16SP A22 5,5/6,3 x L, GT16SP A29 5,5/6,3 x L, GT16SP S19 5,5/6,3 x L, GT16SP S22 5,5/6,3 x L and GT16SP S29 5,5/6,3 x L, with hexagon head and carbon steel, aluminum or stainless steel sealing washer $\varnothing 19, 22$ or 29 mm and with saddle washer										
Component II: t_{II} in [mm]		4,00	5,00	6,00	8,00	10,00	12,00	14,00	$\geq 15,00$	
Component I: $t_{N,1}$ or $t_{N,2}$ in [mm]	$V_{R,k}$ in [kN]	0,50	1,29	1,29	1,29	1,29	1,29	1,29	1,29	1,29
		0,55	1,29	1,29	1,29	1,29	1,29	1,29	1,29	1,29
		0,63	2,35	2,35	2,35	2,35	2,35	2,35	2,35	2,35
		0,75	2,50	2,50	2,50	2,50	2,50	2,50	2,50	2,50
		0,88	2,50	2,50	2,50	2,50	2,50	2,50	2,50	2,50
		1,00	2,50	2,50	2,50	2,50	2,50	2,50	2,50	2,50
	$N_{R,k}$ in [kN]	0,50	3,65	3,65	3,65	7,76	7,76	7,76	7,76	7,76
		0,55	3,65	3,65	3,65	7,76	7,76	7,76	7,76	7,76
		0,63	4,60	4,60	4,60	7,76	7,76	7,76	7,76	7,76
		0,75	5,45	5,45	5,45	7,76	7,76	7,76	7,76	7,76
		0,88	5,45	5,45	5,45	7,76	7,76	7,76	7,76	7,76
		1,00	5,45	5,45	5,45	7,76	7,76	7,76	7,76	7,76
max. head displacement u depending on the sandwich panel thickness in [mm]	30	1	1	1	1	1	1	1	1	
	40	1	1	1	1	1	1	1	1	
	50	1	1	1	1	1	1	1	1	
	60	2,5	2,5	2,5	2,5	2,5	2,5	2,5	2,5	
	70	2,5	2,5	2,5	2,5	2,5	2,5	2,5	2,5	
	80	2,5	2,5	2,5	2,5	2,5	2,5	2,5	2,5	
	90	4	4	4	4	4	4	4	4	
	100	4	4	4	4	4	4	4	4	
	120	4	4	4	4	4	4	4	4	
	≥ 140	4	4	4	4	4	4	4	4	

Component I: S280GD, S320GD or S350GD – EN 10346

Component II: S235 – EN 10025-1 S280GD, S320GD or S350GD – EN 10346

Table 69.

Self-drilling screws GT20SP Z19 5,5/6,3 x L, GT20SP Z22 5,5/6,3 x L, GT20SP Z29 5,5/6,3 x L, GT20SP A19 5,5/6,3 x L, GT20SP A22 5,5/6,3 x L, GT20SP A29 5,5/6,3 x L, GT20SP S19 5,5/6,3 x L, GT20SP S22 5,5/6,3 x L and GT20SP S29 5,5/6,3 x L, with hexagon head and carbon steel, aluminum or stainless steel sealing washer $\varnothing 19, 22$ or 29 mm and with saddle washer										
Component II: t_{II} in [mm]		4,00	5,00	6,00	8,00	10,00	12,00	14,00	$\geq 15,00$	
Component I: $t_{N,1}$ or $t_{N,2}$ in [mm]	$V_{R,k}$ in [kN]	0,50	1,29	1,29	1,29	1,29	1,29	1,29	1,29	1,29
		0,55	1,29	1,29	1,29	1,29	1,29	1,29	1,29	1,29
		0,63	2,35	2,35	2,35	2,35	2,35	2,35	2,35	2,35
		0,75	2,50	2,50	2,50	2,50	2,50	2,50	2,50	2,50
		0,88	2,50	2,50	2,50	2,50	2,50	2,50	2,50	2,50
		1,00	2,50	2,50	2,50	2,50	2,50	2,50	2,50	2,50
	$N_{R,k}$ in [kN]	0,50	3,65	3,65	3,65	7,76	7,76	7,76	7,76	7,76
		0,55	3,65	3,65	3,65	7,76	7,76	7,76	7,76	7,76
		0,63	4,60	4,60	4,60	7,76	7,76	7,76	7,76	7,76
		0,75	5,45	5,45	5,45	7,76	7,76	7,76	7,76	7,76
		0,88	5,45	5,45	5,45	7,76	7,76	7,76	7,76	7,76
		1,00	5,45	5,45	5,45	7,76	7,76	7,76	7,76	7,76
max. head displacement u depending on the sandwich panel thickness in [mm]	30	1	1	1	1	1	1	1	1	
	40	1	1	1	1	1	1	1	1	
	50	1	1	1	1	1	1	1	1	
	60	2,5	2,5	2,5	2,5	2,5	2,5	2,5	2,5	
	70	2,5	2,5	2,5	2,5	2,5	2,5	2,5	2,5	
	80	2,5	2,5	2,5	2,5	2,5	2,5	2,5	2,5	
	90	4	4	4	4	4	4	4	4	
	100	4	4	4	4	4	4	4	4	
	120	4	4	4	4	4	4	4	4	
	≥ 140	4	4	4	4	4	4	4	4	

Component I: S280GD, S320GD or S350GD – EN 10346

Component II: S235 – EN 10025-1 S280GD, S320GD or S350GD – EN 10346

Table 70.

Self-drilling screws GT25SP Z19 5,5/6,3 x L, GT25SP Z22 5,5/6,3 x L, GT25SP Z29 5,5/6,3 x L, GT25SP A19 5,5/6,3 x L, GT25SP A22 5,5/6,3 x L, GT25SP A29 5,5/6,3 x L, GT25SP S19 5,5/6,3 x L, GT25SP S22 5,5/6,3 x L and GT25SP S29 5,5/6,3 x L, with hexagon head and carbon steel, aluminum or stainless steel sealing washer $\varnothing 19, 22$ or 29 mm and with saddle washer										
Component II: t_{II} in [mm]		4,00	5,00	6,00	8,00	10,00	12,00	14,00	$\geq 15,00$	
Component I: $t_{N,1}$ or $t_{N,2}$ in [mm]	$V_{R,k}$ in [kN]	0,50	1,29	1,29	1,29	1,29	1,29	1,29	1,29	1,29
		0,55	1,29	1,29	1,29	1,29	1,29	1,29	1,29	1,29
		0,63	2,35	2,35	2,35	2,35	2,35	2,35	2,35	2,35
		0,75	2,50	2,50	2,50	2,50	2,50	2,50	2,50	2,50
		0,88	2,50	2,50	2,50	2,50	2,50	2,50	2,50	2,50
		1,00	2,50	2,50	2,50	2,50	2,50	2,50	2,50	2,50
	$N_{R,k}$ in [kN]	0,50	3,65	3,65	3,65	7,76	7,76	7,76	7,76	7,76
		0,55	3,65	3,65	3,65	7,76	7,76	7,76	7,76	7,76
		0,63	4,60	4,60	4,60	7,76	7,76	7,76	7,76	7,76
		0,75	5,45	5,45	5,45	7,76	7,76	7,76	7,76	7,76
		0,88	5,45	5,45	5,45	7,76	7,76	7,76	7,76	7,76
		1,00	5,45	5,45	5,45	7,76	7,76	7,76	7,76	7,76
max. head displacement u depending on the sandwich panel thickness in [mm]	30	1	1	1	1	1	1	1	1	
	40	1	1	1	1	1	1	1	1	
	50	1	1	1	1	1	1	1	1	
	60	2,5	2,5	2,5	2,5	2,5	2,5	2,5	2,5	
	70	2,5	2,5	2,5	2,5	2,5	2,5	2,5	2,5	
	80	2,5	2,5	2,5	2,5	2,5	2,5	2,5	2,5	
	90	4	4	4	4	4	4	4	4	
	100	4	4	4	4	4	4	4	4	
	120	4	4	4	4	4	4	4	4	
	≥ 140	4	4	4	4	4	4	4	4	

Component I: S280GD, S320GD or S350GD – EN 10346

Component II: S235 – EN 10025-1 S280GD, S320GD or S350GD – EN 10346

Table 71.

Self-drilling screws GTRWSP A19 6,4/7,0 x L, GTRWSP A22 6,4/7,0 x L, GTRWSP A29 6,4/7,0 x L, GTRWSP S19 6,4/7,0 x L, GTRWSP S22 6,4/7,0 x L and GTRWSP S29 6,4/7,0 x L with hexagon head and aluminum or stainless steel sealing washer Ø19, 22 or 29 mm and with saddle washer				
Component II: wood class ≥ C24		Effective length l_{ef} [mm]		
		≥ 30	≥ 40	
V _{R,k} [kN] dla t _{0,2} [mm]	0,50	1,23	1,23	Failure of component I
	0,55	1,23	1,23	
	0,63	1,63	1,63	
	0,75	1,87	1,87	
	0,88	1,87	1,87	
	1,00	1,87	1,87	
N _{R,k} [kN] dla t _{0,1} [mm]	0,50	4,16	4,37	Failure of component I
	0,55	4,16	4,37	
	0,63	4,16	4,37	
	0,75	4,16	4,37	
	0,88	4,16	4,37	
	1,00	4,16	4,37	
max. head displacement "u" depending on sandwich panel thickness [mm]	30	1,0	1,0	
	40	1,0	1,0	
	50	1,0	1,0	
	60	1,5	1,5	
	70	1,5	1,5	
	80	1,5	1,5	
	90	2,0	2,0	
	100	2,0	2,0	
	120	2,0	2,0	
	≥ 140	2,0	2,0	

Component I: S280GD, S320GD or S350GD – EN 10346

Component II: structural timber – EN 14081

Table 72.

Self-drilling screws GTX6SP S19 5,5/6,3 x L, GTX6SP S22 5,5/6,3 x L and GTX6SP S29 5,5/6,3 x L, with hexagon head and aluminum or stainless steel sealing washer $\varnothing 19, 22$ or 29 mm and with saddle washer									
Component II: t_{II} in [mm]		1,00	1,50	2,00	2,50	3,00	4,00	$\geq 5,00$	
Component I: $t_{I,1}$ or $t_{I,2}$ in [mm]	$V_{R,k}$ in [kN]	0,50	1,40	1,40	1,40	1,40	1,40	1,40	
		0,55	1,40	1,40	1,40	1,40	1,40	1,40	
		0,63	1,60	1,60	1,60	1,60	1,60	1,60	
		0,75	2,10	2,10	2,10	2,10	2,10	2,10	
		0,88	2,10	2,10	2,10	2,10	2,10	2,10	
		1,00	2,10	2,10	2,10	2,10	2,10	2,10	
	$N_{R,k}$ in [kN]	0,50	1,04	1,92	2,56	2,56	2,56	6,50	6,50
		0,55	1,04	1,92	2,56	2,56	2,56	6,50	6,50
		0,63	1,04	1,92	2,56	2,56	2,56	6,50	6,50
		0,75	1,04	1,92	2,56	2,56	2,56	6,50	6,50
		0,88	1,04	1,92	2,56	2,56	2,56	6,50	6,50
		1,00	1,04	1,92	2,56	2,56	2,56	6,50	6,50
max. head displacement u depending on the sandwich panel thickness in [mm]	30	12	12	12	12	1,5	1,5	1,5	
	40	12	12	12	12	1,5	1,5	1,5	
	50	12	12	12	12	1,5	1,5	1,5	
	60	18	18	18	18	4	4	4	
	70	18	18	18	18	4	4	4	
	80	18	18	18	18	4	4	4	
	90	23	23	23	23	10	10	10	
	100	23	23	23	23	10	10	10	
	120	23	23	23	23	10	10	10	
	≥ 140	23	23	23	23	10	10	10	

Component I: S280GD, S320GD or S350GD – EN 10346

Component II: S235 – EN 10025-1 S280GD, S320GD or S350GD – EN 10346

Table 73.

Self-drilling screws GTX12SP S19 5,5/6,3 x L, GTX12SP S22 5,5/6,3 x L and GTX12SP S29 5,5/6,3 x L, with hexagon head and aluminum or stainless steel sealing washer $\varnothing 19, 22$ or 29 mm and with saddle washer								
Component II: t_{II} in [mm]		3,00	4,00	5,00	6,00	8,00	10,00	$\geq 11,00$
Component I: $t_{N,1}$ or $t_{N,2}$ in [mm]	$V_{R,k}$ in [kN]	0,50	1,40	1,40	1,40	1,40	1,40	1,40
		0,55	1,40	1,40	1,40	1,40	1,40	1,40
		0,63	1,60	1,60	1,60	1,60	1,60	1,60
		0,75	2,10	2,10	2,10	2,10	2,10	2,10
		0,88	2,10	2,10	2,10	2,10	2,10	2,10
		1,00	2,10	2,10	2,10	2,10	2,10	2,10
	$N_{R,k}$ in [kN]	0,50	3,06	6,47	6,47	7,88	7,88	7,88
		0,55	3,06	6,47	6,47	7,88	7,88	7,88
		0,63	3,86	6,47	6,47	7,88	7,88	7,88
		0,75	5,39	6,47	6,47	7,88	7,88	7,88
		0,88	5,39	6,47	6,47	7,88	7,88	7,88
		1,00	5,39	6,47	6,47	7,88	7,88	7,88
max. head displacement u depending on the sandwich panel thickness in [mm]	30	1,5	1,5	1,5	1,5	1,5	1,5	
	40	1,5	1,5	1,5	1,5	1,5	1,5	
	50	1,5	1,5	1,5	1,5	1,5	1,5	
	60	4	4	4	4	4	4	
	70	4	4	4	4	4	4	
	80	4	4	4	4	4	4	
	90	6	6	6	6	6	6	
	100	6	6	6	6	6	6	
	120	6	6	6	6	6	6	
	≥ 140	6	6	6	6	6	6	

Component I: S280GD, S320GD or S350GD – EN 10346

Component II: S235 – EN 10025-1 S280GD, S320GD or S350GD – EN 10346

Tabela A3

Dimensions of saddle washer.

Item	Designation	Wave width	Length	Sheet thickness	Opening angle
		A	B	t	α
		[mm]	[mm]	[mm]	[°]
1	Saddle washer	26	41,5	1	25

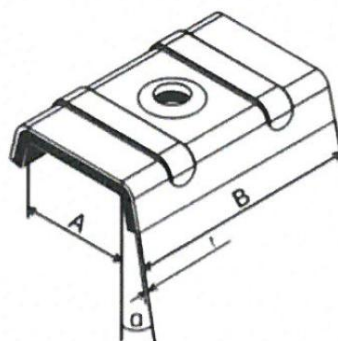

carbon steel $R_m \geq 360$ MPa, galvanized (≥ 200 g/m²), with or without additional coating gRey.coat or aluminum $R_m \geq 360$ MPa (with or without powder coating) or stainless steel 1,4301 acc. to EN 10088 (with or without powder coating)

Tabela A4

Dimensions of GSPW

Item	Designation	Width	Length	Sheet thickness
		Hmin	L	Tmin
		[mm]	[mm]	[mm]
1	GSPW 80/30	22	80	1,2
2	GSPW 100/25	22	100	1,2
3	GSPW 150/25	22	150	1,2
4	GSPW 150/30	22	150	1,2

8. Relevant technical documentation or special technical documentation

Not applicable

Performance properties of the product described above are compatible with the set of declared performance characteristics. This declaration of performance is issued in accordance with Regulation (EU) No 305/2011 under the sole responsibility of the manufacturer referred above

On behalf of the producer signed:

Sewer Malesiniski
 Product Manager
 Singapore Strong-Tie Etanco P.S.A.

Orneta, August 05, 2025