

ZAGZAVOD ZA
GRADBENIŠTVO
SLOVENIJESLOVENIAN
NATIONAL BUILDING
AND CIVIL ENGINEERING
INSTITUTEMember of
www.eota.eu**Dimičeva 12,
1000 Ljubljana, Slovenija**

Tel.: +386 (0)1 280 44 72, +386 (0)1-280 45 37

Fax: +386 (0)1 280 44 84

e-mail: info.ta@zag.si<http://www.zag.si>

European Technical Assessment

ETA-10/0293
of 2. 2. 2023*English version prepared by ZAG*

General Part

**Technical Assessment Body issuing the
European Technical Assessment****ZAG Ljubljana****Trade name of the construction product****FM 753 crack A4****Product family to which the construction
product belongs****33: Torque controlled expansion
anchor made of stainless steel of
sizes M8, M10, M12 and M16 for use
in concrete****Manufacturer****FRIULSIDER S.p.A.
via Trieste 1
33048 San Giovanni al Natisone (UD)
Italy
www.friulsider.com****Manufacturing plant****FRIULSIDER S.p.A.
via Trieste 1
33048 San Giovanni al Natisone (UD)
Italy****This European Technical Assessment
contains****13 pages including 3 annexes, which form
an integral part of the document****This European Technical Assessment is
issued in according to Regulation (EU)
No 305/2011, on the basis of****EAD 330232-01-0601,
edition December 2019****This Assessment replaces****ETA-10/0293 issued on 17.7.2015**

Translations of this European Technical Assessment in other languages shall fully correspond to the original issued document and should be identified as such.

Communication of this European Technical Assessment, including transmission by electronic means, shall be in full (excepted the confidential Annex(es) referred to above). However, partial reproduction may be made, with the written consent of the issuing Technical Assessment Body. Any partial reproduction has to be identified as such.

Specific Parts

1 Technical description of the product

The FM-753 crack A4 in the ranges of M8, M10, M12 and M16 is an anchor made of stainless steel, which is placed into a drilled hole and anchored by torque-controlled expansion.

For the installed anchor see Figures given in Annex A (1/2).

2 Specification of the intended use(s) in accordance with the applicable European Assessment Document (hereinafter EAD)

The performances given in Chapter 3 are only valid if the anchor is used in compliance with the specifications and conditions given in Annex B.

The provisions made in this European Technical Assessment are based on an assumed working life of the anchor of 50 years. The indications given on the working life cannot be interpreted as a guarantee given by the manufacturer, but are to be regarded only as a means for choosing the right products in relation to the expected economically reasonable working life of the works.

3 Performance of the product and references to the methods used for this assessment

3.1 Mechanical resistance and stability (BWR 1)

The basic work requirements for mechanical resistance and stability are listed in Annexes C (1/6) and C (2/6) for static and quasi-static loading and in Annexes C (3/6) and C (4/6) for seismic performance.

3.2 Safety in case of fire (BWR 2)

The basic work requirements for safety in case of fire are listed in Annex C (5/6 and C (6/6).

3.8 General aspects relating to fitness for use

Durability and serviceability are only ensured if specifications of intended use according to Annex B (1/2) are kept.

4 Assessment and verification of constancy of performance (hereinafter AVCP) system applied, with reference to its legal base

According to the decision 96/582/EC of the European Commission¹ the system of assessment and verification of constancy of performance (see Annex V to regulation (EU) No 305/2011) **1** apply.

5 Technical details necessary for the implementation of the AVCP system, as provided for on the applicable EAD

Technical details necessary for the implementation of the AVCP system are laid down in chapter 3 of EAD 330232-01-0601.

Issued in Ljubljana on 2. 2. 2023

Signed by:

Franc Capuder, M.Sc., Research Engineer

Head of Service of TAB



¹ Official Journal of the European Communities L 254 of 8.10.1996

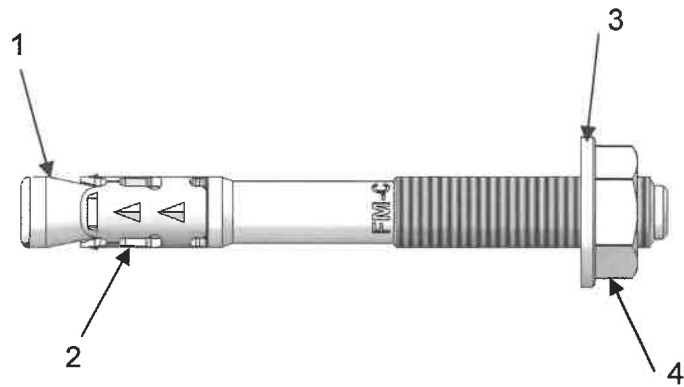

- 1 Anchor bolt (body)
- 2 Expansion sleeve
- 3 Washer
- 4 Hexagonal nut

Figure A1: FM 753 crack A4 anchor

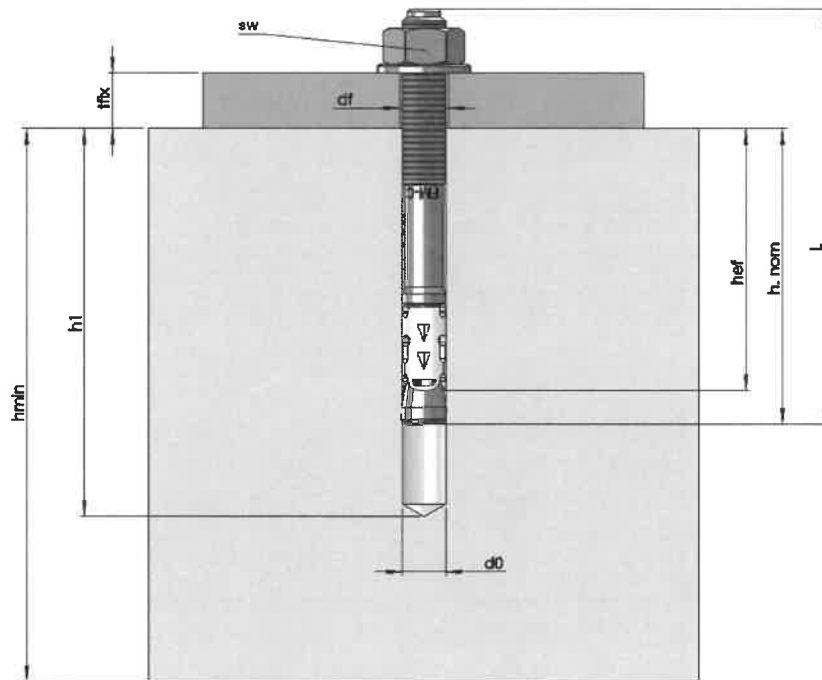

Figure A2: Installed FM 753 crack A4 anchor

FM 753 crack A4	Annex A (1/2)
Product description Product and installation condition	

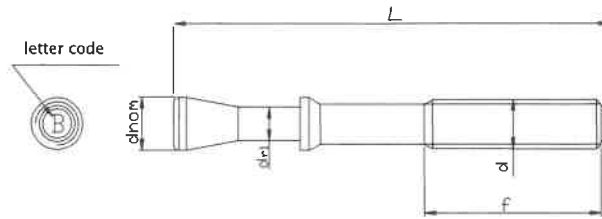

Table A1: Dimensions and marking

	dxL	Marking	Letter code ID	L (mm)	d _{nom} (mm)	d _{r1} (mm)	f (mm)
M8	M8x68	FM-C 8/4 A4	A	68	8	5,8	30
	M8x75	FM-C 8/10 A4	B	75			30
	M8x90	FM-C 8/25 A4	C	90			40
	M8x115	FM-C 8/50 A4	D	115			60
	M8x135	FM-C 8/70 A4	E	135			80
	M8x165	FM-C 8/100 A4	G	165			80
M10	M10x90	FM-C 10/10 A4	A	90	10	7,4	40
	M10x105	FM-C 10/25 A4	B	105			55
	M10x115	FM-C 10/35 A4	C	115			55
	M10x135	FM-C 10/55 A4	D	135			85
	M10x155	FM-C 10/75 A4	E	155			85
	M10x185	FM-C 10/105 A4	F	185			85
M12	M12x110	FM-C 12/10 A4	A	110	12	8,8	65
	M12x120	FM-C 12/20 A4	B	120			65
	M12x130	FM-C 12/30 A4	P	130			65
	M12x145	FM-C 12/45 A4	C	145			85
	M12x170	FM-C 12/70 A4	D	170			85
	M12x200	FM-C 12/100 A4	E	200			85
M16	M16x130	FM-C 16/10 A4	A	130	16	11,8	65
	M16x150	FM-C 16/30 A4	B	150			85
	M16x185	FM-C 16/60 A4	C	185			85
	M16x220	FM-C 16/100 A4	D	220			85

Table A2: Materials

Part	Component	Material	Coating
1	Anchor body (bolt)	Stainless steel acc. to EN 10088-3	
2	Expansion sleeve	Stainless steel acc. to EN 10088-2	*
3	Washer	DIN 125/1 A4 (normal), DIN 9021 A4 (large) Stainless steel AISI 316 similar acc. to EN 10088-2	
4	Hexagonal nut	DIN 934 A4-80 Stainless Steel AISI 316 similar acc. to ISO 3506-2	*

*Functional coating

FM 753 crack A4	Annex A (2/2)
Product description Dimensions, marking and materials	

Specifications of intended use

Anchorage subjected to:

- Static, quasi static, seismic load and fire.

Base materials:

- Cracked and non-cracked concrete.
- Reinforced and unreinforced normal weight concrete of strength class C20/25 at minimum and C50/60 at maximum according to EN 206:2013+A2:2021.

Use conditions (Environmental conditions):

- The anchor may be used in concrete subject to dry internal conditions and also in concrete subject to external atmospheric exposure (including industrial and marine environment), or exposure in permanent damp internal conditions, if no particular aggressive conditions exist.

Note: Particular aggressive conditions are e.g. permanent, alternating immersion in seawater or splash zone of seawater, chloride atmosphere of indoor swimming pools or atmosphere with extreme chemical pollution (e.g. desulphurization plants or road tunnels where de-icing materials are used)

Design:

- Anchorages are designed under the responsibility of an engineer experienced in anchorages and concrete work.
- Anchorages under static and quasi-static actions are designed in accordance EN 1992-4:2018.
- For seismic application the anchorages are designed in accordance with EN 1992-4:2018, Annex C.
- For application with resistance under fire exposure the anchorages are designed in accordance with method given in EN 1992-4:2018, Annex D.
- Verifiable calculation notes and drawings are prepared taking into account of the load to be anchored. The position of the anchor is indicated on the design drawings (e.g. position of the anchor relative to reinforcement or to supports, etc.).

Installation:

- Anchor installation carried out by appropriately qualified personnel and under supervision of the person responsible for technical matters of the site.
- Use of the anchor only supplied by the manufacturer without exchanging the components of an anchor.
- Anchor installation in accordance with the manufacturer's specification and drawings and using the appropriate tools.
- Checks before placing the anchor to ensure that the strength class of the concrete in which the anchor is to be placed is in the range given and is not lower than that of the concrete to which the characteristic loads apply for.
- Check of concrete being well compacted, e.g. without significant voids.
- Effective anchorage depth, edge distances and spacing not less than the specified values without minus tolerances.
- Hole drilling by hammer drill.
- Cleaning of the hole of drilling dust.
- Positioning of the drill holes without damaging the reinforcement.
- Application of specified torque moment using a calibrated torque wrench.
- In case of aborted hole, drilling of new hole at a minimum distance of twice the depth of the aborted hole, or smaller distance provided the aborted drill hole is filled with high strength mortar and no shear or oblique tension loads in the direction of aborted hole.

FM 753 crack A4	Annex B (1/2)
Intended use Specifications	

Table B1: Installation data

	$d \times l$	ID	d_a (mm)	d_f (mm)	$h_{cf,STE}$ (mm)	$h_{cf,REE}$ (mm)	$t_{fix,max}$ $h_{cf,STE}$ (mm)	$t_{fix,max}$ $h_{cf,REE}$ (mm)	h_1 $h_{cf,STE}$ (mm)	h_2 $h_{cf,REE}$ (mm)	h_{nom} $h_{cf,STE}$ (mm)	h_{nom} $h_{cf,REE}$ (mm)	h_{min} $h_{cf,STE}$ (mm)	h_{min} $h_{cf,REE}$ (mm)	T_{inst} (Nm)	SW (mm)
M8	M8 × 68	A	8	9	48	34	4	18	70	56	54	40	100	80	20	13
	M8 × 75	B					10	24								
	M8 × 90	C					25	39								
	M8 × 115	D					50	64								
	M8 × 135	E					70	84								
	M8 × 165	G					100	114								
M10	M10 × 90	A	10	12	60	40	10	30	80	60	67	47	120	100	40	17
	M10 × 105	B					25	45								
	M10 × 115	C					35	55								
	M10 × 135	D					55	75								
	M10 × 155	E					75	95								
	M10 × 185	F					105	125								
M12	M12 × 110	A	12	14	72	52	10	30	100	80	81	61	150	120	60	19
	M12 × 120	B					20	40								
	M12 × 130	P					30	50								
	M12 × 145	C					45	65								
	M12 × 170	D					70	90								
	M12 × 200	E					100	120								
M16	M16 × 130	A	16	18	86	66	10	30	115	95	97	77	170	150	120	24
	M16 × 150	B					30	50								
	M16 × 185	C					60	80								
	M16 × 220	D					100	120								

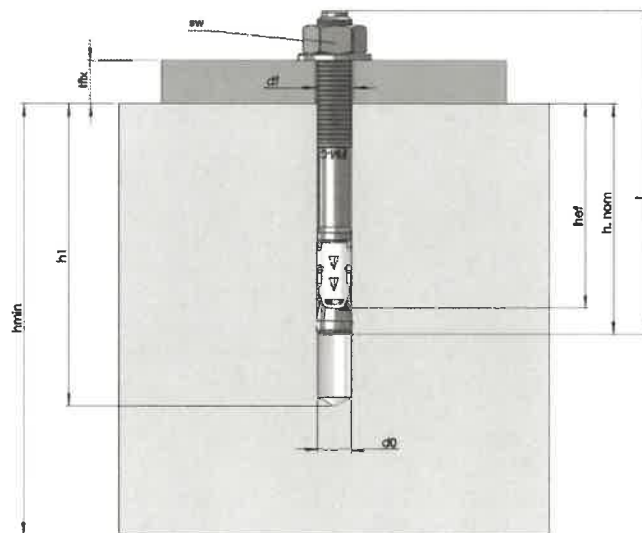

FM 753 crack A4

**Intended use
Installation data**

Annex B (2/2)

Table C1: Characteristic values for Tension loads in case of static and quasi-static loading for design method A acc. to EN 1992-4:2018

Essential characteristics			Performance							
			M8		M10		M12		M16	
			red	std	red	std	red	std	red	std
Installation parameters										
d_o	Nominal diameter of drill bit	[mm]	8		10		12		16	
h_{nom}	Anchorage depth	[mm]	40	54	47	67	61	81	77	97
h_{ef}	Effective anchorage depth	[mm]	34	48	40	60	52	72	66	86
h_{min}	Minimum thickness of concrete member	[mm]	80	100	100	120	120	150	150	170
T_{inst}	Torque moment	[Nm]	20		40		60		120	
s_{min}	Minimum spacing	[mm]	60	50	80	55	60	60	100	70
$c \geq$	Edge distance	[mm]	60	50	70	70	80	80	130	100
c_{min}	Minimum edge distance	[mm]	60	50	50	50	60	60	80	70
$s \geq$	Spacing	[mm]	60	50	110	110	120	120	160	130
Tension steel failure mode										
$N_{Rk,s}$	Characteristic tension steel failure	[kN]	17,2		28,0		39,5		71,1	
γ_{MsN}	Partial safety factor	(-)	1,56							
Pull-out failure mode										
$N_{Rk,p}$	Characteristic pull-out failure in non-cracked concrete	[kN]	7	10	9	16	16	22	25	/ ¹⁾
$N_{Rk,p}$	Characteristic pull-out failure in cracked concrete	[kN]	4,5	6,5	7	10	/ ¹⁾	13	16	26
γ_{inst}	Partial safety factor	(-)	1,0							
γ_{Mp}	Partial safety factor	(-)	1,5							
$s_{cr,N}$	Characteristic spacing	[mm]	$3 \times h_{ef}$							
$c_{cr,N}$	Characteristic edge distance	[mm]	$1,5 \times h_{ef}$							
ψ_c C30/37	Increasing factor for $N_{Rk,p}$ in non-cracked concrete	(-)	1,14	1,22	1,22	1,20	1,11	1,12	1,20	1,19
ψ_c C40/50		(-)	1,26	1,41	1,41	1,37	1,21	1,22	1,37	1,34
ψ_c C50/60		(-)	1,36	1,58	1,58	1,52	1,29	1,31	1,52	1,48
Concrete Cone failure mode										
k_{cr}	Factor for cracked concrete EN 1992-4:2018 § 7.2.1.4	(-)	7,7							
k_{ucr}	Factor for un-cracked concrete EN 1992-4:2018 § 7.2.1.4	(-)	11							
γ_{Mc}	Partial safety factor	(-)	1,5							
Splitting failure mode										
$s_{cr,sp}$	Characteristic spacing	[mm]	102	150	120	180	156	216	198	258
$c_{cr,sp}$	Characteristic edge distance	[mm]	51	75	60	90	78	108	99	129
γ_{Msp}	Partial safety factor	(-)	1,5							
Displacement under tension load										
Non-cracked concrete C20/25										
N	Service tension load	[kN]	3,3	4,8	4,3	7,6	7,6	10,5	11,9	18,7
δ_{N0}	Short term displacement	[mm]	0,013	0,097	0,023	0,170	0,041	0,311	0,533	0,059
$\delta_{N\infty}$	Long term displacement	[mm]	1,550	2,188	1,148	2,460	2,558	1,978	2,116	2,150
Cracked concrete C20/25										
N	Service tension load	[kN]	2,1	3,1	3,3	4,8	6,1	6,2	8,6	12,4
δ_{N0}	Short term displacement	[mm]	0,350	0,885	0,256	0,694	0,439	0,394	0,467	0,733
$\delta_{N\infty}$	Long term displacement	[mm]	1,550	2,188	1,148	2,460	2,558	1,978	2,116	2,150

¹⁾ The pull-out is not decisive

FM 753 crack A4	Annex C (1/6)
Performance Characteristic resistance under tension load	

Table C2: Characteristic values for Shear loads in case of static and quasi-static loading for design method A acc. to EN 1992-4:2018

Essential characteristics			Performance							
			M8		M10		M12		M16	
			red	std	red	std	red	std	red	std
Steel failure without lever arm										
$V_{Rk,s}$	Characteristic resistance	[kN]	15,5		24,4		31,5		62,4	
γ_{Ms}	Partial safety factor	[Nm]	1,3							
k_7	Factor for considering ductility	[-]	1,0							
Steel failure with lever arm										
$M^0_{Rk,s}$	Characteristic resistance	[Nm]	24		49		85		216	
γ_{Ms}	Partial safety factor	[mm]	1,3							
Concrete pryout failure										
k_s	k-factor	[-]	1,0				2,0			
γ_{Mc}	Partial safety factor	[-]	1,5							
Concrete edge failure										
l_{ef}	Effective length of anchor under shear load	[mm]	34	48	40	60	52	72	66	86
d_{nom}	Outside diameter of anchor	[mm]	8		10		12		16	
γ_{Mc}	Partial safety factor	[-]	1,5							
Displacement under shear load										
V	Service shear load	[kN]	8,5		13,4		17,3		34,3	
δ_{V0}	Short term displacement	[mm]	1,014		2,459		1,492		3,557	
$\delta_{V\infty}$	Long term displacement	[mm]	1,521		3,689		2,238		5,336	

FM 753 crack A4

Performance
Characteristic resistance under shear load

Annex C (2/6)

Table C3: Characteristic resistance in case of seismic action for design acc. to EN 1992-4:2018, Annex C: Performance Category C1

Essential characteristics			Anchor size							
			M8		M10		M12		M16	
			red	std	red	std	red	std	red	std
Tension – steel failure										
$N_{Rk,s,seis,C1}$	Characteristic resistance C1	[kN]	/	17,2	/	28,0	/	39,5	/	71,1
$\gamma_{Ms,N^{1)}$	Partial safety factor	[-]	1,56							
Tension – pull-out failure										
$N_{Rk,p,seis,C1}$	Characteristic resistance C1	[kN]	/	5,0	/	10,0	/	13,0	/	26,0
$\gamma_{Mp,N^{1)}$	Partial safety factor	[-]	1,5 ²⁾							
Concrete cone and splitting failure ³⁾										
h_{ef}	Effective anchorage depth	[mm]	/	48	/	60	/	72	/	86
$\gamma_{Mc,N^{1)}$	Partial safety factor $\gamma_{Msp,seis^{1)}$	[-]	1,5 ²⁾							
Shear – steel failure without lever arm										
$V_{Rk,s,seis,C1}$	Characteristic resistance C1	[kN]	/	10,4	/	15,9	/	18,3	/	44,9
$\gamma_{Ms,V^{1)}$	Partial safety factor	[-]	1,3							
Concrete pryout and concrete edge failure ³⁾										
h_{ef}	Effective anchorage depth	[mm]	/	48	/	60	/	72	/	86
$\gamma_{Mc,V^{1)}$	Partial safety factor	[-]	1,5 ²⁾							

¹⁾ In absence of other national regulations

²⁾ The installation safety factor of $\gamma_{inst} = 1,0$ is included

³⁾ For concrete cone, splitting, pryout and edge failure, see EN 1992-4:2018

FM 753 crack A4	Annex C (3/6)
Performance Characteristic resistance under seismic action Performance category C1	

Table C3: Characteristic resistance in case of seismic action for design acc. to EN 1992-4:2018, Annex C: Performance Category C2

Essential characteristics			Anchor size							
			M8		M10		M12		M16	
			red	std	red	std	red	std	red	std
Tension – steel failure										
$N_{Rk,s,seis,C2}^{2)}$	Characteristic resistance C2	[kN]	/	17,2	/	28,0	/	39,5	/	71,1
$\gamma_{Ms,N}^{3)}$	Partial safety factor	[-]	1,56							
Tension – pull-out failure										
$N_{Rk,p,seis,C2}$	Characteristic resistance C2	[kN]	/	1,75	/	2,3	/	8,7	/	21,8
$\gamma_{Mp,N}^{3)}$	Partial safety factor	[-]	1,5							
$\delta_{N,sei(DLS)}^{1)2)}$	Displacement at DLS	[mm]	/	5,70	/	2,92	/	4,85	/	6,28
$\delta_{N,sei(ULS)}^{1)2)}$	Displacement at ULS	[mm]	/	18,47	/	15,80	/	15,66	/	21,04
Shear – steel failure without lever arm										
$V_{Rk,s,seis,C2}$	Characteristic resistance C2	[kN]	/	7,1	/	15,9	/	18,3	/	44,9
$\gamma_{Ms,V}^{3)}$	Partial safety factor	[-]	1,3							
$\delta_{V,sei(DLS)}^{1)2)}$	Displacement at DLS	[mm]	/	2,63	/	2,37	/	5,15	/	5,99
$\delta_{V,sei(ULS)}^{1)2)}$	Displacement at ULS	[mm]	/	7,80	/	4,08	/	9,69	/	10,71

1) The listed displacement represent mean values

2) A smaller displacement may be required in the design in the case of displacement sensitive fastenings or “rigid” supports. The characteristic resistance associated with such smaller displacement may be determined by linear interpolation or proportional reduction.

3) The recommended partial safety factors under seismic action ($\gamma_{M,seis}$) are the same as for static loading

FM 753 crack A4	Annex C (4/6)
Performance Characteristic resistance under seismic action Performance category C2	

Table C3: Characteristic resistance under tension loads in case of fire exposure for design acc. to EN 1992-4:2018, Annex D

Essential characteristics				Anchor size							
				M8		M10		M12		M16	
				red	std	red	std	red	std	red	std
Steel failure											
$N_{Rk,s,fi}$	Characteristic resistance	R30	[kN]	0,53		1,08		1,82		3,28	
		R60	[kN]	0,42		0,86		1,52		2,74	
		R90	[kN]	0,32		0,69		1,22		2,19	
		R120	[kN]	0,26		0,60		0,97		1,75	
Pull-out failure											
$N_{Rk,p,fi}$	Characteristic resistance	R30	[kN]	1,13	1,50	1,75	2,50	/ ¹⁾	3,25	4,00	6,50
		R60	[kN]	1,13	1,50	1,75	2,50	/ ¹⁾	3,25	4,00	6,50
		R90	[kN]	1,13	1,50	1,75	2,50	/ ¹⁾	3,25	4,00	6,50
		R120	[kN]	0,90	1,20	1,40	2,00	/ ¹⁾	2,60	3,20	5,20
Concrete cone and splitting failure²⁾											
$N^0_{Rk,c,fi}$	Characteristic resistance	R30	[kN]	1,16	2,75	1,74	4,80	3,36	7,57	6,09	11,81
		R60	[kN]	1,16	2,75	1,74	4,80	3,36	7,57	6,09	11,81
		R90	[kN]	1,16	2,75	1,74	4,80	3,36	7,57	6,09	11,81
		R120	[kN]	0,92	2,20	1,39	3,84	2,69	6,06	4,87	9,45
$S_{cr,N,fi}$	Spacing	[mm]	4 x h_{ef}								
S_{min}		[mm]	60	50	80	50	60	60	100	70	
$C_{cr,N,fi}$	Edge distance	[mm]	2 x h_{ef}								
C_{min}		[mm]	Fire attack from one side: $C_{min} = 2 \times h_{ef}$ Fire attack from more than one side: $C_{min} \geq 300 \text{ mm}$ and $\geq 2 \times h_{ef}$								

¹⁾ Pull-out isn't decisive

²⁾ As a rule, splitting failure can be neglected when cracked concrete and reinforcement is assumed

Design under fire exposure is performed according to the design method given in EN 1992-4:2018, Annex D.

Under fire exposure usually cracked concrete is assumed. The design equations are given in EN 1992-4:2018, Annex D.

In the absence of other national regulations the partial safety factor for resistance under fire exposure $\gamma_{M,fi} = 1,0$ is recommended.

FM 753 crack A4

Performance

Characteristic shear resistance under fire exposure

Annex C (5/6)

Table C4: Characteristic resistance under shear loads in case of fire exposure for design acc. to EN 1992-4:2018, Annex D

Essential characteristics				Anchor size							
				M8		M10		M12		M16	
				red	std	red	std	red	std	red	std
Steel failure without lever arm											
$V_{Rk,s,fi}$	Characteristic resistance	R30	[kN]	0,73	1,45	2,53	4,71				
		R60	[kN]	0,59	1,16	2,11	3,93				
		R90	[kN]	0,44	0,93	1,69	3,14				
		R120	[kN]	0,37	0,81	1,35	2,51				
Steel failure with lever arm											
$M^0_{Rk,s,fi}$	Characteristic resistance	R30	[Nm]	0,73	1,87	3,93	9,97				
		R60	[Nm]	0,59	1,49	3,28	8,31				
		R90	[Nm]	0,44	1,19	2,62	6,65				
		R120	[Nm]	0,37	1,04	2,10	5,32				
Concrete pryout failure											
	k-factor	k_8	[-]	1,0				2,0			
$V^0_{Rk,c,fi}$	Characteristic resistance	R30	[kN]	1,16	2,75	1,74	9,60	6,72	15,14	12,18	23,62
		R60	[kN]	1,16	2,75	1,74	9,60	6,72	15,14	12,18	23,62
		R90	[kN]	1,16	2,75	1,74	9,60	6,72	15,14	12,18	23,62
		R120	[kN]	0,92	2,20	1,39	7,68	5,38	12,12	9,74	18,90
Concrete edge failure											
The initial value $V^0_{Rk,c,fi}$ of the characteristic resistance in concrete C20/25 to C50/60 under fire exposure may be determined by:											
$V^0_{Rk,c,fi} = 0,25 \times V^0_{Rk,c} \quad (\leq R90) \quad \quad V^0_{Rk,c,fi} = 0,20 \times V^0_{Rk,c} \quad (R120)$											
with $V^0_{Rk,c}$ initial value of the characteristic resistance in cracked concrete C20/25 under normal temperature.											

Design under fire exposure is performed according to the design method given in EN 1992-4:2018, Annex D. Under fire exposure usually cracked concrete is assumed. The design equations are given in EN 1992-4:2018, Annex D. covers design for fire exposure from one side. For fire attack from more than one side the edge distance must be increased to $c_{min} \geq 300$ mm and $\geq 2 \times h_{ef}$.

In the absence of other national regulations the partial safety factor for resistance under fire exposure $\gamma_{M,fi} = 1,0$ is recommended.

FM 753 crack A4

Performance

Characteristic shear resistance under fire exposure

Annex C (6/6)