

## European Technical Assessment

## ETA-09/0056 of 24/01/2022

English translation prepared by CSTB - Original version in French language

### General Part

*Nom commercial*  
Trade name

**FM753 Crack**

*Famille de produit*  
Product family

***Cheville métallique à expansion par vissage à couple contrôlé, de fixation dans le béton fissuré et non fissuré diamètres M8, M10, M12 et M16***

**Torque-controlled expansion fastener for use in cracked and uncracked concrete: sizes M8, M10, M12 and M16**

*Titulaire*  
Manufacturer

FRIULSIDER  
Via Trieste, 1  
I 33048 San Giovanni al Natisone (UDINE)  
Italy

*Usine de fabrication*  
Manufacturing plants

Plant 1

*Cette évaluation contient:*  
This Assessment contains

*14 pages incluant 11 annexes qui font partie intégrante de cette évaluation*  
14 pages including 11 annexes which form an integral part of this assessment

*Base de l'ETE*  
Basis of ETA

DEE 330232-01-0601, Décembre 2019  
EAD 330232-01-0601, December 2019

*Cette évaluation remplace:*  
This Assessment replaces

ETE-09/0056 valide à compter du 18/07/2017  
ETA-09/0056 with validity dated from 18/07/2017

*Translations of this European Technical Assessment in other languages shall fully correspond to the original issued document and should be identified as such. Communication of this European Technical Assessment, including transmission by electronic means, shall be in full. However, partial reproduction may be made, with the written consent of the issuing Technical Assessment Body. Any partial reproduction has to be identified as such.*

## Specific Part

### 1 Technical description of the product

The FM753 Crack fastener is made of zinc electroplated steel which is placed into a drilled hole and anchored by torque-controlled expansion.

The illustration and the description of the product are given in Annex A.

### 2 Specification of the intended use

The performances given in Section 3 are only valid if the fastener is used in compliance with the specifications and conditions given in Annexes B.

The provisions made in this European technical assessment are based on an assumed working life of the fastener of 50 years. The indications given on the working life cannot be interpreted as a guarantee given by the producer, but are to be regarded only as a means for choosing the right products in relation to the expected economically reasonable working life of the works.

### 3 Performance of the product

#### 3.1 Mechanical resistance and stability (BWR 1)

Essential characteristic	Performance
Characteristic tension resistance	See Annex C1
Characteristic shear resistance	See Annex C2
Displacements	See Annex C3
Characteristic resistance under seismic action C1	See Annex C4
Characteristic resistance under seismic action C2	See Annex C5

#### 3.2 Safety in case of fire (BWR 2)

Essential characteristic	Performance
Reaction to fire	Fasteners satisfy requirements for Class A1
Characteristic tension resistance under fire	See Annex C6
Characteristic shear resistance under fire	See Annex C7

#### 3.3 Hygiene, health and the environment (BWR 3)

Regarding dangerous substances contained in this European technical assessment, there may be requirements applicable to the products falling within its scope (e.g. transposed European legislation and national laws, regulations and administrative provisions). In order to meet the provisions of the Construction Products Directive, these requirements need also to be complied with, when and where they apply.

### 3.4 Safety in use (BWR 4)

For basic requirement safety in use the same criteria are valid as for basic requirement mechanical resistance and stability.

### 3.5 Protection against noise (BWR 5)

Not relevant.

### 3.6 Energy economy and heat retention (BWR 6)

Not relevant.

### 3.7 Sustainable use of natural resources (BWR 7)

For the sustainable use of natural resources no performance was determined for this product.

### 3.8 General aspects relating to fitness for use

Durability and Serviceability are only ensured if the specifications of intended use according to Annex B1 are kept.

## 4 Assessment and verification of constancy of performance (AVCP)

According to the Decision 96/582/EC of the European Commission<sup>1</sup>, as amended, the system of assessment and verification of constancy of performance (see Annex V to Regulation (EU) No 305/2011) given in the following table apply.

Product	Intended use	Level or Class	System
Metal fasteners for use in concrete	For fixing and/or supporting to concrete, structural elements (which contributes to the stability of the works) or heavy units	—	1

## 5 Technical details necessary for the implementation of the AVCP system

Technical details necessary for the implementation of the Assessment and verification of constancy of performance (AVCP) system are laid down in the control plan deposited at Centre Scientifique et Technique du Bâtiment.

The manufacturer shall, on the basis of a contract, involve a notified body approved in the field of fasteners for issuing the certificate of conformity CE based on the control plan.

Issued in Marne-la-Vallée on 24/01/2022 by

Head of the Structure, Masonry and Partition Division      *The original French version is signed*

Anca Cronopol

---

<sup>1</sup> Official Journal of the European Communities L 254 of 08.10.1996

**Installed condition**

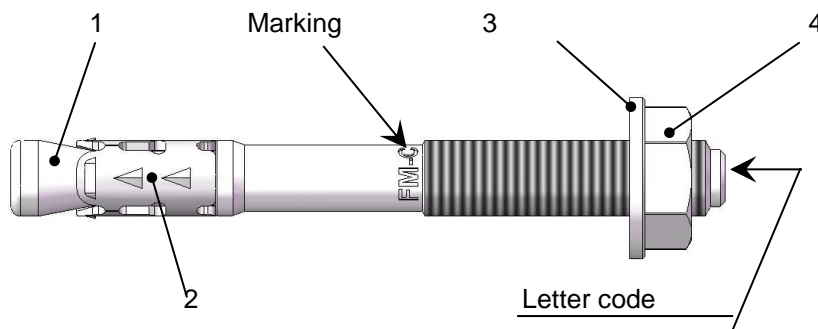

- 1. Bolt
- 2. Expansion sleeve
- 3. Washer
- 4. Hexagonal nut

**Marking on the bolt:**

FM-C (product name)

followed by MX/Y where

MX = thread diameter  
 Y = fixture thickness

**Table A1: Materials**

Part	Designation	Material	Protection
1	Bolt	M8 and M10: C-steel according to EN 10269	Galvanised $\geq 8 \mu\text{m}$
		M12 and M16: C-steel according to EN 10263-4	
2	Expansion sleeve	Stainless steel according to EN 10088/2	-
3	Washer	C-steel DIN 125/1 (normal), DIN 9021 (large)	Galvanised $\geq 8 \mu\text{m}$
4	Hexagonal nut	C-steel DIN 934, steel grade 8	Galvanised $\geq 8 \mu\text{m}$

**FM753 Crack expansion fastener**

**Product description**  
 Installed condition and product description

**Annex A1**

## Specifications of intended use

### Fasteners subject to:

- Static or quasi-static loads.
- Seismic actions for Performance Category C1 and C2.
- Fire exposure.

### Base materials:

- Reinforced or unreinforced normal weight concrete according to EN 206:2013+ A1:2016.
- Strength classes C20/25 to C50/60 according to EN 206:2013+A1:2016.
- Cracked and uncracked concrete.

### Use conditions (Environmental conditions):

- Structures subject to dry indoor conditions, indoor with temporary condensation.

### Design:

- The fasteners are designed in accordance with EN 1992-4 "Design of concrete structures – Part 4: Design of fastenings for use in concrete" under the responsibility of an engineer experienced in fasteners and concrete work.
- For seismic application, the fasteners are designed in accordance with EN 1992-4, Annex C "Design of fastenings under seismic actions".
- For application with resistance under fire exposure, the fasteners are designed in accordance with EN 1992-4, Annex D "Exposure to fire – design method".
- Verifiable calculation notes and drawings are prepared taking account of the loads to be anchored. The position of the fastener is indicated on the design drawings.

### Installation:

- Fastener installation carried out by appropriately qualified personnel and under the supervision of the person responsible for technical matters of the site.
- Use of the fastener only as supplied by the manufacturer without exchanging the components of a fastener.
- Fastener installation in accordance with the manufacturer's specifications and drawings and using the appropriate tools.
- Effective anchorage depth, edge distances and spacing not less than the specified values without minus tolerances.
- In case of aborted hole, drilling of new hole at a minimum distance of twice the depth of the aborted hole, or smaller distance provided the aborted drill hole is filled with high strength mortar and no shear or oblique tension loads in the direction of aborted hole.

FM753 Crack expansion fastener

Annex B1

Intended use  
Specifications

**Table B1: Specifications of intended use**

	$d \times L$	Marking	Letter code ID	$L$ (mm)	$d_{nom}$ (mm)	$d_{r1}$ (mm)	$f$ (mm)
<b>M8</b>	M8 × 68	FM-C 8/4	A	68	8	5,8	30
	M8 × 75	FM-C 8/10	B	75			30
	M8 × 90	FM-C 8/25	C	90			40
	M8 × 115	FM-C 8/50	D	115			60
	M8 × 135	FM-C 8/70	E	135			80
	M8 × 165	FM-C 8/100	G	165			80
<b>M10</b>	M10 × 90	FM-C 10/10	A	90	10	7,4	40
	M10 × 105	FM-C 10/25	B	105			55
	M10 × 115	FM-C 10/35	C	115			55
	M10 × 135	FM-C 10/55	D	135			85
	M10 × 155	FM-C 10/75	E	155			85
	M10 × 185	FM-C 10/105	F	185			85
<b>M12</b>	M12 × 110	FM-C 12/10	A	110	12	8,8	65
	M12 × 120	FM-C 12/20	B	120			65
	M12 × 145	FM-C 12/45	C	145			85
	M12 × 170	FM-C 12/70	D	170			85
	M12 × 200	FM-C 12/100	E	200			85
<b>M16</b>	M16 × 130	FM-C 16/10	A	130	16	11,8	65
	M16 × 150	FM-C 16/30	B	150			85
	M16 × 185	FM-C 16/60	C	185			85
	M16 × 220	FM-C 16/100	D	220			85

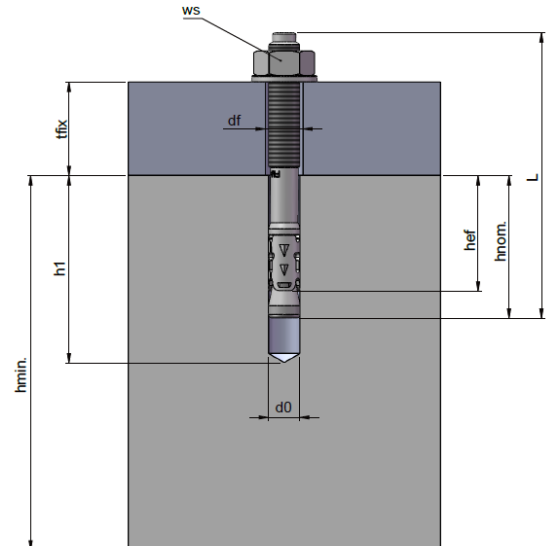
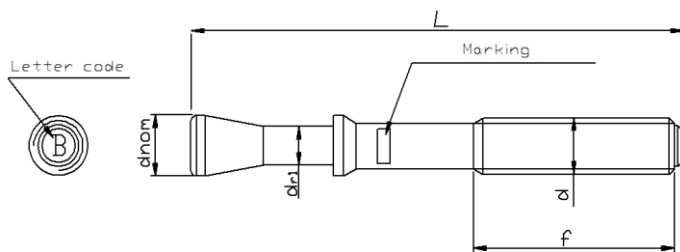

**FM753 Crack expansion fastener**

**Intended use**  
 Specifications of intended use and fastener dimensions  
 Installation parameters

**Annex B2**

## Installation instruction

**Table B2: Fastener dimensions**

	$d \times L$	ID	$d_0$ (mm)	$d_f$ (mm)	$h_{ef,STD}$ (mm)	$h_{ef,RED}$ (mm)	$t_{fix,max}$ $h_{ef,STD}$ (mm)	$t_{fix,max}$ $h_{ef,RED}$ (mm)	$h_1$ $h_{ef,STD}$ (mm)	$h_1$ $h_{ef,RED}$ (mm)	$h_{nom}$ $h_{ef,STD}$ (mm)	$h_{nom}$ $h_{ef,RED}$ (mm)	$h_{min}$ $h_{ef,STD}$ (mm)	$h_{min}$ $h_{ef,RED}$ (mm)	$T_{inst}$ (Nm)	$SW$ (mm)
<b>M8</b>	M8 x 68	A	8	9	48	34	4	18	70	56	54	40	100	80	20	13
	M8 x 75	B					10	24								
	M8 x 90	C					25	39								
	M8 x 115	D					50	64								
	M8 x 135	E					70	84								
	M8 x 165	G					100	114								
<b>M10</b>	M10 x 90	A	10	12	60	40	10	30	80	60	67	47	120	100	40	17
	M10 x 105	B					25	45								
	M10 x 115	C					35	55								
	M10 x 135	D					55	75								
	M10 x 155	E					75	95								
	M10 x 185	F					105	125								
<b>M12</b>	M12 x 110	A	12	14	72	52	10	30	100	80	81	61	150	120	60	19
	M12 x 120	B					20	40								
	M12 x 145	C					45	65								
	M12 x 170	D					70	90								
	M12 x 200	E					100	120								
	<b>M16</b>	M16 x 130					A	16								
M16 x 150		B	30	50												
M16 x 185		C	60	80												
M16 x 220		D	100	120												

FM753 Crack			M8		M10		M12		M16	
Effective embedment depth	$h_{ef}$	[mm]	34	48	40	60	52	72	66	86
Min. member thickness	$h_{min}$	[mm]	80	100	100	120	120	150	150	170
Minimum edge distance	$c_{min}$	[mm]	51	50	100	60	100	70	120	85
	$s \geq$	[mm]	102	75	180	120	200	150	120	170
Minimum spacing	$s_{min}$	[mm]	102	50	180	60	200	70	120	80
	$c \geq$	[mm]	51	65	100	80	100	90	120	120

**FM753 Crack expansion fastener**

**Intended use**

Specifications of intended use and fastener dimensions  
 Installation parameters

**Annex B3**

**Table C1: Characteristic resistance under tension load in case of static and quasi-static loading**

Size			M8		M10		M12		M16	
Effective embedment depth	$h_{ef}$	[mm]	34	48	40	60	52	72	66	86
<b>Steel failure</b>										
Partial safety factor	$\gamma_{Ms}^{1)}$	[-]	1,5							
Characteristic resistance	$N_{Rk,s}$	[kN]	23,7		38,7		54,7		98,4	
<b>Pull-out failure</b>										
Characteristic resistance in concrete C20/25										
Installation safety factor	$\gamma_{inst}$	[-]	1,0							
Uncracked concrete	$N_{Rk,p,ucr}$	[kN]	7,5	9,0	10,0	16,0	20,0	20,0	30,0	35,0
Cracked concrete	$N_{Rk,p,cr}$	[kN]	1,5	6,0	4,5	12,0	6,5	16,0	19,0	20,0
Increasing factor concrete strength $\psi_c$	C30/37	[-]	1,22							
	C40/50	[-]	1,41							
	C50/60	[-]	1,55							
<b>Concrete cone and splitting failure</b>										
Installation safety factor	$\gamma_{inst}$	[-]	1,0							
Factor for uncracked concrete	$k_{ucr,N}$	[-]	11,0							
Factor for cracked concrete	$k_{cr,N}$	[-]	7,7							
Spacing	$s_{cr,N}$	[mm]	102	144	180	180	200	220	198	120
Edge distance	$c_{cr,N}$	[mm]	51	72	100	90	100	110	99	120
Spacing (splitting)	$s_{cr,sp}$	[mm]	204	290	240	360	354	430	396	520
Edge distance (splitting)	$c_{cr,sp}$	[mm]	102	145	120	180	177	215	198	260

<sup>1)</sup> In absence of other national regulations

**FM753 Crack expansion fastener**

**Performances**  
 Characteristic resistance under tension load

**Annex C1**



**Table C2: Characteristic resistance under shear load in case of static and quasi-static loading**

Size			M8		M10		M12		M16	
Effective embedment depth	$h_{ef}$	[mm]	34	48	40	60	52	72	66	86
<b>Steel failure without lever arm</b>										
Partial safety factor	$\gamma_{Ms}^{1)}$	[-]	1,5							
Ductility factor	$k_7$	[-]	1,0							
Characteristic resistance	$V_{Rk,s}$	[kN]	12,9		24,2		33,8		66,4	
<b>Steel failure with lever arm</b>										
Partial safety factor	$\gamma_{Ms}^{1)}$	[-]	1,5							
Ductility factor	$k_7$	[-]	1,0							
Characteristic bending resistance	$M_{Rk,s}^0$	[N·m]	33,4		66,9		117,7		299,1	
<b>Concrete pry-out failure</b>										
Pry-out factor	$k_8$	[-]	1,0		1,0	2,0	1,0	2,0	2,0	
Installation safety factor	$\gamma_{inst}$	[-]	1,0							
<b>Concrete edge failure</b>										
Effective length of fastener under shear loading	$l_f = h_{ef}$	[mm]	34	48	40	60	52	72	66	86
Outside diameter of fastener	$d_{nom}$	[mm]	8		10		12		16	
Installation safety factor	$\gamma_{inst}$	[-]	1,0							

<sup>1)</sup> In absence of other national regulations

**FM753 Crack expansion fastener**

**Performances**  
 Characteristic resistance under shear load

**Annex C2**

**Table C3: Displacements under tension load in case of static and quasi-static loading**

Size			M8		M10		M12		M16	
Effective embedment depth	$h_{ef}$	[mm]	34	48	40	60	52	72	66	86
Tension load in uncracked concrete C20/25	$N$	[kN]	3,57	4,29	4,76	7,62	9,52	9,52	14,29	16,67
Displacement	$\delta_{N0}$	[mm]	0,03	0,10	0,12	0,10	1,71	0,10	0,06	0,10
	$\delta_{N\infty}$	[mm]	1,45	0,50	1,63	0,50	1,66	0,50	2,05	0,50
Tension load in uncracked concrete C50/60	$N$	[kN]	5,65	6,64	7,53	11,91	15,06	14,76	22,59	25,83
Displacement	$\delta_{N0}$	[mm]	0,25	0,10	0,12	0,20	0,74	0,20	0,14	0,30
	$\delta_{N\infty}$	[mm]	1,45	0,50	1,63	0,50	1,66	0,50	2,05	0,50
Tension load in cracked concrete C20/25	$N$	[kN]	0,71	2,86	2,14	5,71	3,10	7,62	9,05	9,52
Displacement	$\delta_{N0}$	[mm]	0,50	1,40	0,41	1,20	1,05	0,90	2,05	0,60
	$\delta_{N\infty}$	[mm]	1,45	1,40	1,63	1,20	1,63	1,30	2,05	0,60
Tension load in cracked concrete C50/60	$N$	[kN]	1,13	4,43	3,39	8,86	4,89	11,81	14,31	14,76
Displacement	$\delta_{N0}$	[mm]	1,29	1,80	0,48	1,80	1,40	1,80	1,46	1,80
	$\delta_{N\infty}$	[mm]	1,45	1,80	1,63	1,80	1,66	1,80	2,05	1,80

**Table C4: Displacements under shear load in case of static and quasi-static loading**

Size			M8		M10		M12		M16	
Effective embedment depth	$h_{ef}$	[mm]	34	48	40	60	52	72	66	86
Tension load in cracked and uncracked concrete C20/25 to C50/60	$V$	[kN]	6,14		11,52		16,10		31,62	
Displacement	$\delta_{V0}$	[mm]	2,50		1,77		1,05		2,19	
	$\delta_{V\infty}$	[mm]	3,75		2,66		1,58		3,28	

<sup>1)</sup> Additional displacement due to anular gap between fastener and fixture is to be taken into account.

**FM753 Crack expansion fastener**

**Performances**  
 Displacements under static or quasi static loading

**Annex C3**

**Table C5: Characteristic resistance under tension load in case of seismic category C1**

Size		M8	M10	M12	M16
Effective embedment depth	$h_{ef}$ [mm]	48	60	72	86
<b>Steel failure</b>					
Partial safety factor	$\gamma_{Ms,C1}^{1)}$ [-]	1,5			
Characteristic resistance	$N_{Rk,s,C1}$ [kN]	23,8	38,7	54,7	98,4
<b>Pull-out failure</b>					
Installation safety factor	$\gamma_{inst}$ [-]	1,0			
Characteristic resistance	$N_{Rk,p,C1}$ [kN]	6	12	16	20
<b>Concrete cone failure</b>					
Installation safety factor	$\gamma_{inst}$ [-]	1,0			

<sup>1)</sup> In absence of other national regulations

**Table C6: Characteristic resistance under shear load in case of seismic category C1**

Size		M8	M10	M12	M16
Effective embedment depth	$h_{ef}$ [mm]	48	60	72	86
<b>Steel failure without lever arm</b>					
Partial safety factor	$\gamma_{Ms,C1}^{1)}$ [-]	1,5			
Characteristic resistance	$V_{Rk,s,C1}$ [kN]	7,7	17,0	30,4	57,6
<b>Concrete pry-out failure</b>					
Installation safety factor	$\gamma_{inst}$ [-]	1,0			
<b>Concrete edge failure</b>					
Installation safety factor	$\gamma_{inst}$ [-]	1,0			

<sup>1)</sup> In absence of other national regulations

**FM753 Crack expansion fastener**

**Performances**

Characteristic resistance under seismic action category C1

**Annex C4**

**Table C7: Characteristic resistance under tension load in case of seismic category C2**

Size			M10	M12	M16
Effective embedment depth	$h_{ef}$	[mm]	60	72	86
<b>Steel failure</b>					
Partial safety factor	$\gamma_{Ms,C2}^{1)}$	[-]	1,5		
Characteristic resistance	$N_{Rk,s,C2}$	[kN]	38,7	54,7	98,4
<b>Pull-out failure</b>					
Installation safety factor	$\gamma_{inst}$	[-]	1,0		
Characteristic resistance	$N_{Rk,p,C2}$	[kN]	3,3	11,8	20,0
<b>Concrete cone failure</b>					
Installation safety factor	$\gamma_{inst}$	[-]	1,0		

<sup>1)</sup> In absence of other national regulations

**Table C8: Characteristic resistance under shear load in case of seismic category C2**

Size			M10	M12	M16
Effective embedment depth	$h_{ef}$	[mm]	60	72	86
<b>Steel failure without lever arm</b>					
Partial safety factor	$\gamma_{Ms,C2}^{1)}$	[-]	1,5		
Characteristic resistance	$V_{Rk,s,C2}$	[kN]	11,9	19,3	31,2
<b>Concrete pry-out failure</b>					
Installation safety factor	$\gamma_{inst}$	[-]	1,0		
<b>Concrete edge failure</b>					
Installation safety factor	$\gamma_{inst}$	[-]	1,0		

<sup>1)</sup> In absence of other national regulations

**Table C9: Displacements under tension load in case of seismic category C2**

Size			M10	M12	M16
Effective embedment depth	$h_{ef}$	[mm]	60	72	86
Displacement DLS	$\delta_{N,C2(DLS)}$	[mm]	2,5	5,0	4,4
Displacement ULS	$\delta_{N,C2(ULS)}$	[mm]	10,7	20,4	17,8

**Table C10: Displacements under shear load in case of seismic category C2**

Size			M10	M12	M16
Effective embedment depth	$h_{ef}$	[mm]	60	72	86
Displacement DLS	$\delta_{V,C2(DLS)}$	[mm]	5,0	7,0	7,0
Displacement ULS	$\delta_{V,C2(ULS)}$	[mm]	7,1	9,1	6,6

**FM753 Crack expansion fastener**

**Performances**

Characteristic resistance under seismic action category C2

Displacements under seismic action category C2

**Annex C5**

**Table C11: Characteristic resistance under tension load in cracked and uncracked concrete under fire exposure<sup>1)2)</sup>**

Size		M8		M10		M12		M16	
Effective embedment depth	$h_{ef}$ [mm]	34	48	40	60	52	72	66	86
<b>Steel failure</b>									
Characteristic resistance	$N_{Rk,s,fi(30)}$ [kN]	0,26		0,65		1,22		2,19	
	$N_{Rk,s,fi(60)}$ [kN]	0,24		0,56		0,91		1,64	
	$N_{Rk,s,fi(90)}$ [kN]	0,18		0,91		0,79		1,42	
	$N_{Rk,s,fi(120)}$ [kN]	0,13		1,64		0,61		1,09	
<b>Pull-out failure</b>									
Char. resistance in concrete $\geq$ C20/25	$N_{Rk,p,fi(30)}$ [kN]	0,38	1,50	1,13	3,00	1,63	4,00	4,75	5,00
	$N_{Rk,p,fi(60)}$ [kN]								
	$N_{Rk,p,fi(90)}$ [kN]								
	$N_{Rk,p,fi(120)}$ [kN]	0,30	1,20	0,90	2,40	1,30	3,20	3,80	4,00
<b>Concrete cone and splitting failure<sup>3)</sup></b>									
Char. resistance in concrete $\geq$ C20/25	$N_{Rk,c,fi(30)}^0$ [kN]	1,16	2,75	1,74	4,80	3,36	7,57	6,09	11,81
	$N_{Rk,c,fi(60)}^0$ [kN]								
	$N_{Rk,c,fi(90)}^0$ [kN]								
	$N_{Rk,c,fi(120)}^0$ [kN]	0,93	2,20	1,39	3,84	2,69	6,06	4,87	9,45
Characteristic spacing	$s_{cr,N,fi}$ [mm]	136	192	160	240	208	288	264	344
Characteristic edge distance	$c_{cr,N,fi}$ [mm]	68	96	80	120	104	144	132	172

<sup>1)</sup> Design under fire exposure is performed according to the design method given in EN 1992-4. Under fire exposure usually cracked concrete is assumed. The design equations are given in EN 1992-4, Annex D.

<sup>2)</sup> EN 1992-4 covers design for fire exposure from one side. For fire attack from more than one side the edge distance must be increased to  $c_{min} \geq 300$  mm and  $\geq 2 \cdot h_{ef}$ .

<sup>3)</sup> As a rule, splitting failure can be neglected when cracked concrete and reinforcement is assumed.

<sup>4)</sup> In absence of other national regulations the partial safety factor for resistance under fire exposure  $\gamma_{M,fi} = 1,0$  is recommended.

**FM753 Crack expansion fastener**

**Performances**

Characteristic resistance for tension load under fire exposure

**Annex C6**

**Table C12: Characteristic resistance under shear load in cracked and uncracked concrete under fire exposure<sup>1)2)</sup>**

Size		M8		M10		M12		M16	
Effective embedment depth	$h_{ef}$ [mm]	34	48	40	60	52	72	66	86
<b>Steel failure without lever arm</b>									
Characteristic resistance	$V_{Rk,s,fi(30)}$ [kN]	0,26		0,65		1,22		2,19	
	$V_{Rk,s,fi(60)}$ [kN]	0,24		0,56		0,91		1,64	
	$V_{Rk,s,fi(90)}$ [kN]	0,18		0,91		0,79		1,42	
	$V_{Rk,s,fi(120)}$ [kN]	0,13		1,64		0,61		1,09	
<b>Steel failure with lever arm</b>									
Characteristic bending moment	$M_{Rk,s,fi(30)}^0$ [N·m]	0,37		1,12		2,62		4,99	
	$M_{Rk,s,fi(60)}^0$ [N·m]	0,33		0,97		1,96		4,32	
	$M_{Rk,s,fi(90)}^0$ [N·m]	0,26		0,74		1,70		4,32	
	$M_{Rk,s,fi(120)}^0$ [N·m]	0,19		0,60		1,31		3,32	
<b>Concrete pry-out failure</b>									
Pry-out factor	$k_b$ [-]	1,0		1,0	2,0	1,0	2,0	2,0	
Characteristic resistance ≥ C20/25	$V_{Rk,cp,fi(30)}$ [kN]	1,16	2,75	1,74	4,80	3,36	7,57	12,19	23,62
	$V_{Rk,cp,fi(60)}$ [kN]								
	$V_{Rk,cp,fi(90)}$ [kN]								
	$V_{Rk,cp,fi(120)}$ [kN]	0,93	2,20	1,39	3,84	2,69	6,06	9,75	18,89
<b>Concrete edge failure</b>									
Effective length of fastener under shear loading	$l_f = h_{ef}$ [mm]	34	48	40	60	52	72	66	86
Outside diameter of fastener	$d_{nom}$ [mm]	8		10		12		16	

1) Design under fire exposure is performed according to the design method given in EN 1992-4. Under fire exposure usually cracked concrete is assumed. The design equations are given in EN 1992-4, Annex D.

2) EN 1992-4 covers design for fire exposure from one side. For fire attack from more than one side the edge distance must be increased to  $c_{min} \geq 300$  mm and  $\geq 2 \cdot h_{ef}$ .

**FM753 Crack expansion fastener**

**Performances**

Characteristic resistance for shear load under fire exposure

**Annex C7**